

# Power Supply Reference Manual - 24V, 40 A Single-phase Input

Catalog Number 1606-XLS960E

Topic	Page	Topic	Page
AC Input	3	Front Side and User Elements	13
Input Inrush Current	4	EMC	14
DC Input	4	Environment	15
Output	5	Protection Features	16
Hold-up Time	7	Safety Features	16
DC-OK Relay Contact	7	Dielectric Strength	17
Shut-down Input	8	Standards and Certifications	17
Remote Control of Output Voltage	9	Approximate Dimensions	18
Internal Data Logging	9	Intended Use	18
Efficiency and Power Losses	10	Installation Requirements	18
Lifetime Expectancy and MTBF	11	Accessories	19
Functional Diagram	11	Application Notes	20
Terminal and Wiring	12		

## 1606-XLS960E 24V, 40 A, Single-phase Input Power Supply

The Bulletin 1606-XLS DIN-rail power supplies are efficient and small. Achieved by a synchronous rectification, a bridge-less PFC circuit, and some additional unique design details.

Large power reserves of 150% and built-in large sized output capacitors support the starting of heavy loads such as DC motors or capacitive loads. The use of a unit from a lower wattage class can be used to save space and cost.

High immunity to transients and power surges and low electromagnetic emissions makes usage in nearly every environment possible.

The integrated input fuse and the near zero input inrush current make installation and usage simple. Diagnostics are easy due to the DC-OK relay, a green DC-OK LED, and the red overload LED.

A large international approval package for various applications makes this unit suitable for nearly every application.

- AC 100-240V Wide-range Input
- Width only 125 mm (4.9 in.), Weight only 1.9 kg (4.2 lb.)
- 94.6% Full Load and Excellent Partial Load Efficiencies
- 50% BonusPower®, 1440 W for up to 4 s
- 110 A High Peak Current for 10 ms for Easy Fuse Tripping
- Safe HiccupPLUS Overload Mode
- Active PFC (Power Factor Correction)
- Negligible Low Input Inrush Current Surge
- Full Power Between -25...+60 °C (-13...140 °F)
- Current Sharing Feature for Parallel Use
- Internal Data Logging for Troubleshooting Included.
- Remote Control of Output Voltage
- DC-OK Relay Contact
- Shut-down Input
- ATEX and IECEx Approved



Attribute		Value
Output Voltage	nom	24V DC nominal
	Adjustment range	24 ... 28V DC
Output Current	Continuous	40 ... 34.3A
	Short Term (4 seconds)	60 ... 51.5A
Output Power	Continuous	960 W
	Short Term (4 seconds)	1440 W
Output Ripple, 20 Hz to 20 MHz		< 100mVpp
Input Voltage, -15%/+10%		100 ... 240V AC
Frequency, ± 6%		50 ... 60 Hz
AC Inrush Current, at 120/230V AC		17/ 11 A peak
Efficiency at 120/230V AC		93.6/94.6%
Losses at 120/230V AC		65.6 / 54.8 W
Temperature, operating		-25 ... +70°C
Derating		24 W / °C +60 ... 70°C between 85 ... 90V AC
Hold-up Time		27/27 ms
Dimensions W x H x D		125 x 124 x 127 mm (4.9 x 4.88 x 5 in.)
Weight		1900 g / 4.2 lb.

## AC Input

Attribute	Value	Notes
AC input	nom. 100...240V AC	suitable for TN, TT, and IT mains networks
AC input range	min 90...264V AC	continuous operation
	min 85...90V AC	< 55 °C (131 °F) ambient temperature continuously allowed > 55 °C (131 °F) ambient temperature short term or with output derating according to <a href="#">Output Current vs. Ambient Temperature on page 15</a>
	min 60...85V AC	full power for up to 200 ms
	min 0...85V AC	no damage to the unit
	min 264...300V AC	< 500 ms
Allowed voltage L or N to earth	max 300V AC	continuous, IEC 62103
Input frequency	nom. 50...60Hz	±6%
Turn-on voltage	typ 80V AC	steady-state value, load-independent, see <a href="#">Figure 1</a>
Shut-down voltage	typ 74V AC	
External input protection	See <a href="#">External Input Protection on page 22</a> .	

Attribute		100V AC	120V AC	230V AC	Notes
Input current	typ	10.5 A	8.6 A	4.5 A	at 24V, 40 A, see <a href="#">Figure 3</a>
Power factor <sup>(1)</sup>	typ	0.99	0.99	0.99	at 24V, 40 A, see <a href="#">Figure 4</a>
Crest factor <sup>(2)</sup>	typ	1.47	1.53	1.56	at 24V, 40 A
Start-up delay	typ	800 ms	750 ms	700 ms	see <a href="#">Figure 2</a>
Rise time	typ	15 ms	15 ms	15 ms	at 24V, 40 A, resistive load, 0 mF see <a href="#">Figure 2</a>
	typ	18 ms	18 ms	18 ms	at 24V, 40 A, resistive load, 40mF see <a href="#">Figure 2</a>
Turn-on overshoot	max	100 mV	100 mV	100 mV	see <a href="#">Figure 2</a>

- (1) The power factor is the ratio of the true (or real) power to the apparent power in an AC circuit.  
 (2) The crest factor is the mathematical ratio of the peak value to RMS value of the input current waveform.

**Figure 1 - Input Voltage Range**

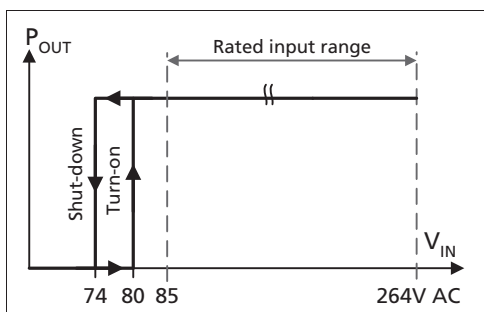

**Figure 2 - Turn-on Behavior, Definitions**

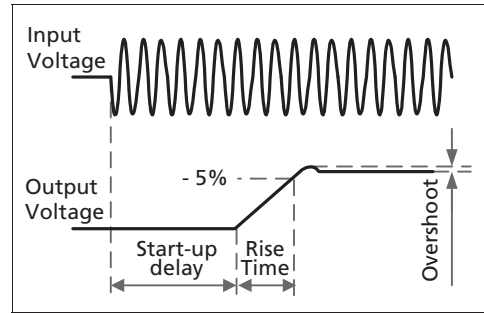

**Figure 3 - Input Current vs. Output Load at 24V**

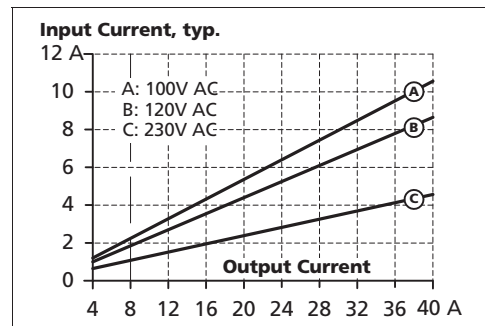

**Figure 4 - Power Factor vs. Output Load at 24V**

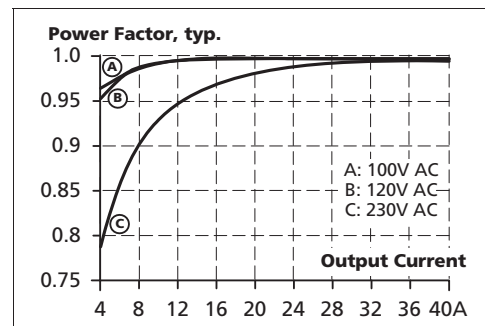

## Input Inrush Current

negligible low value. The input current is smaller than the steady state input current.

The power supply is equipped with an active inrush current limitation circuit, which limits the input inrush current after turn-on to a

Attribute		Value <sup>(2)</sup>		
		100V AC	120V AC	230V AC
Inrush Current <sup>(1)</sup>	Max	25 A	22 A	16 A
	Typ	20 A	17 A	11 A
Inrush Energy	Max	5 A <sup>2</sup>	5 A <sup>2</sup>	5 A <sup>2</sup>

(1) The charging current into EMI suppression capacitors is disregarded in the first microseconds after switch-on.

(2) Over entire temperature range, mains interruptions >1 second.

**Figure 5 - Typical Turn-on Behavior at Nominal Load and 25 °C (77 °F) Ambient Temperature**

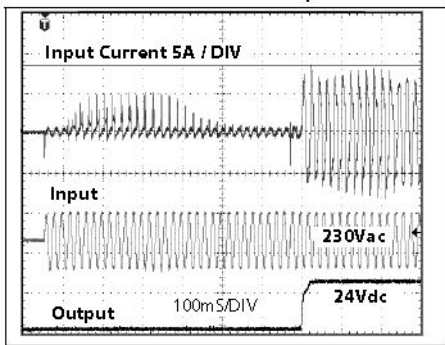

## DC Input

Do not operate this power supply with DC input voltage.

## Output

Attribute		Value	
Output	nom	24V DC	
Adjustment range	min	24-28V DC	guaranteed
	max	29V DC <sup>(1)</sup>	at clockwise end position of potentiometer
Factory setting	typ	24.1V DC	±0.2%, at full load, cold unit, in "single use" mode
	typ	24.1V DC	±0.5%, at full load, cold unit, in "parallel use" mode
	typ	25.1V DC	at no load, cold unit, in "parallel use" mode
Line regulation	max	10 mV	85...300V AC
Load regulation	max	50 mV	in "single use" mode: static value, 0 A..40 A, see <a href="#">Figure 6 on page 6</a>
	typ	1000 mV	in "parallel use" mode: static value, 0 A..40 A, see <a href="#">Figure 10 on page 7</a>
Ripple and noise voltage	max	100mVpp	20 Hz to 20 MHz, 50 Ohms
Output current	nom	40 A	continuously available at 24V, see <a href="#">Figure 6</a> and <a href="#">Figure 10 on page 7</a>
	nom	34.3 A	continuously available at 28V, see <a href="#">Figure 6</a> and <a href="#">Figure 10 on page 7</a>
	nom	60 A	short-term available BonusPower®, at 24V for typical 4 s, see <a href="#">Figure 6</a> and <a href="#">Figure 10 on page 7</a>
	nom	51.5 A	short-term available BonusPower®, at 28V for typical 4 s, see <a href="#">Figure 6</a> and <a href="#">Figure 10 on page 7</a>
	typ	110 A	up to 10 ms, output voltage stays above 20V, see <a href="#">Figure 8 on page 6</a> , This peak current is available once every second. See <a href="#">Peak Current Capability on page 21</a> for more peak current measurements.
Output power	nom	960 W	continuously available at 24-28V
	nom	1440 W <sup>(2)</sup>	short-term available BonusPower® at 24...28V
BonusPower® time	typ	4 s	duration until the output voltage dips, see <a href="#">Figure 8 on page 6</a>
BonusPower® recovery time	typ	7 s	overload free time to reset power manager, see <a href="#">Figure 12 on page 7</a>
Overload behavior	cont. current		output voltage > 20V DC, see <a href="#">Figure 6 on page 6</a>
	HiccupPLUS mode <sup>(3)</sup>		output voltage < 20V DC, see <a href="#">Figure 6 on page 6</a>
Short-circuit current	min	60 A <sup>(4)</sup>	load impedance 25m0hm, see <a href="#">Figure 7 on page 6</a>
	max	70 A	load impedance 25m0hm, see <a href="#">Figure 7 on page 6</a>
	max	23 A	average (R.M.S.) current, load impedance 25m0hm, see <a href="#">Figure 7 on page 6</a>
	typ	130 A	up to 10 ms, load impedance <10m0hm, see <a href="#">Figure 11 on page 7</a>
Output capacitance	typ	10 200 µF	included in the power supply

(1) BonusPower®, short-term power capability (up to typ 4 s) The power supply is designed to support loads with a higher short-term power requirement without damage or shutdown. The short-term duration is hardware that is controlled by an output power manager. This BonusPower® is repeatedly available. If the power supply is loaded longer with the BonusPower® than shown in the Bonus-time diagram (See [Figure 8 on page 6](#)), the max output power is automatically reduced to 960 W. If the power requirement is continuously above 960 W and the voltage falls below approx. 20V (due to the current regulating mode at overload), the unit shuts-off and makes periodical restart attempts. This behavior is called hiccup mode that is described below. If the voltage is above 20V, the unit continuously delivers current.

(2) HiccupPLUS Mode Up to 4 s of overloading, the power supply delivers continuous output current. After this, the output power is reduced to nearly zero for approx. 17 s before a new start attempt is automatically performed. If the overload has been cleared, the device will operate normally. If the overload still exists, the output current will be delivered for 2s to 4s (depending on the overload) again followed by a 17 s rest time. This cycle is repeated as long as the overload exists. See [Figure 7 on page 6](#). During the off-period, a small rest voltage and rest current is present on the output.

(3) Discharge current of output capacitors is not included

(4) This is the maximum output voltage that can occur at the clockwise end position of the potentiometer due to tolerances. It is not guaranteed value that can be achieved. The typical value is about 28.5V.

Figure 6 - Output Voltage vs. Output Current in "Single Use mode" typ

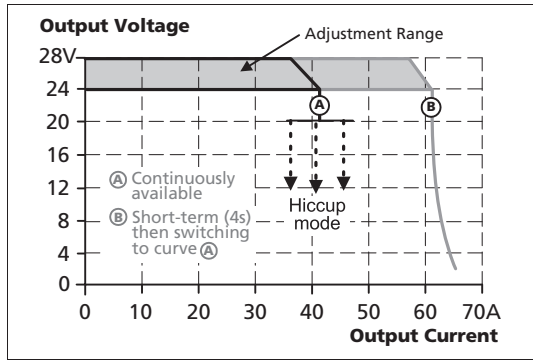

Figure 7 - Short-circuit on output, HiccupPLUS mode, typ

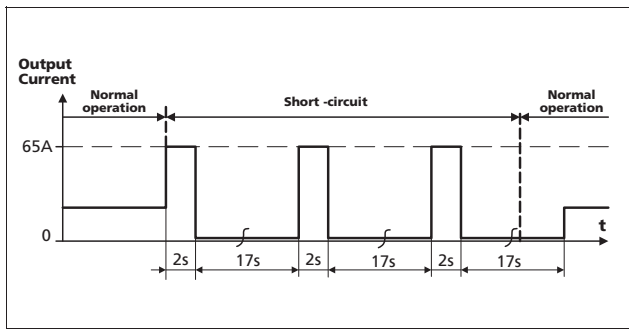

Figure 8 - Bonus time vs. output power

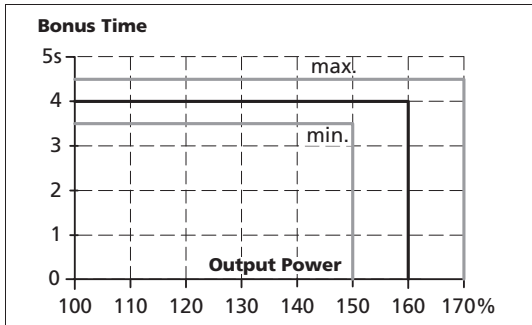
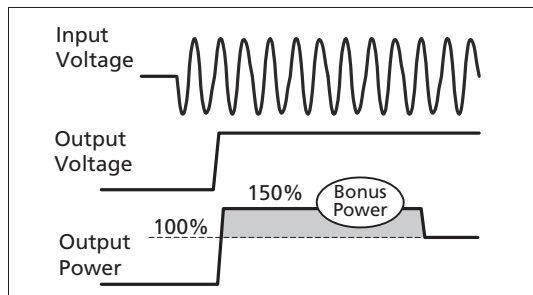
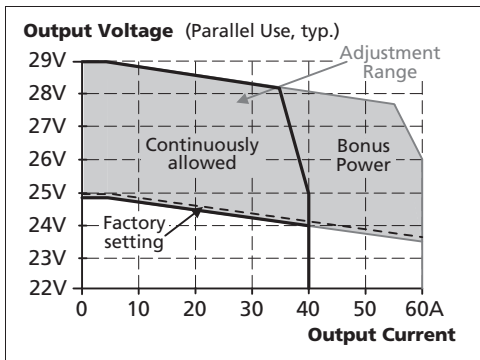

Figure 9 - BonusPower® after input turn-on



**Figure 10 - Output voltage vs. output current in “parallel use” mode, typ**



**Figure 11 - Dynamic overcurrent capability, typ**

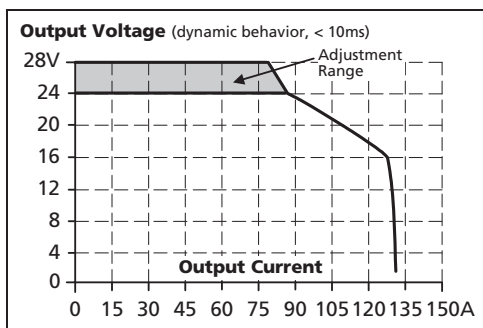

**Figure 12 - BonusPower® recovery time<sup>(1)</sup>**

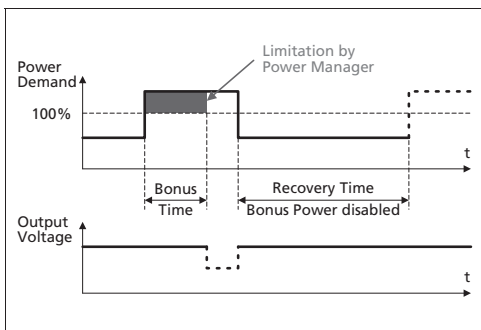

**BonusPower® after output short**

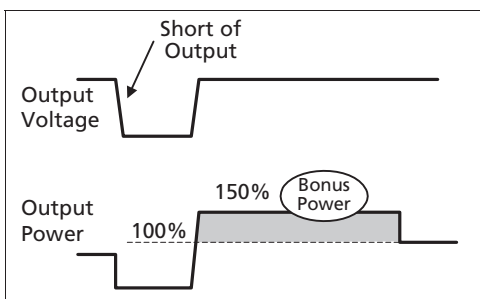

(1) The BonusPower is available as soon as power comes on and after the end of an output short circuit or output overload.

**Hold-up Time**

	100V AC	120V AC	230V AC	
typ	54 ms	54 ms	54 ms	at 24V, 20 A, see <a href="#">Figure 13</a>
min	45 ms	45 ms	45 ms	at 24V, 20 A, see <a href="#">Figure 13</a>
typ	27 ms	27 ms	27 ms	at 24V, 40 A, see <a href="#">Figure 13</a>
min	23 ms	23 ms	23 ms	at 24V, 40 A, see <a href="#">Figure 13</a>

**Figure 13 - Hold-up Time vs. Input Voltage**

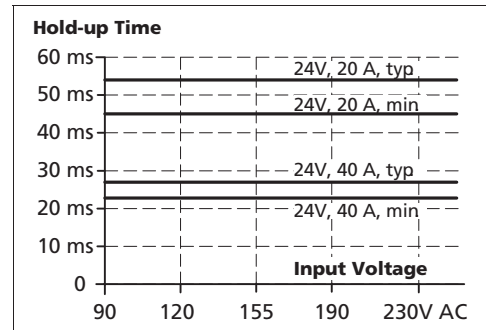

**Figure 14 - Shut Down Behavior, Definitions**

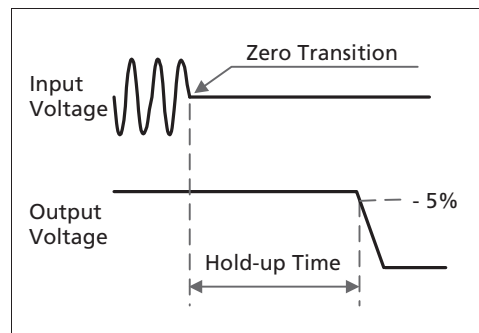

**DC-OK Relay Contact**

This feature monitors the output voltage produced by the power supply. It is independent of a back-fed voltage from a unit that is connected in parallel to the power supply output.

Attribute	Value
Contact closes	As soon as the output voltage reaches 90% of the adjusted output voltage.
Contact opens	As soon as the output voltage dips more than 10% below the adjusted output voltage. Short dips will be extended to a signal length of 250 ms. Dips shorter than 1 ms will be ignored.
Contact recloses	As soon as the output voltage exceeds 90% of the adjusted voltage.

Attribute		Value	
Contact ratings	max	60V DC 0.3 A, 30V DC 1 A, 30V AC 0.5 A	resistive load
	min	1 mA at 5V DC	min permissible load
Isolation voltage		Refer to <a href="#">Dielectric Strength on page 17</a>	

**Figure 15 - DC-OK Relay Contact Behavior**

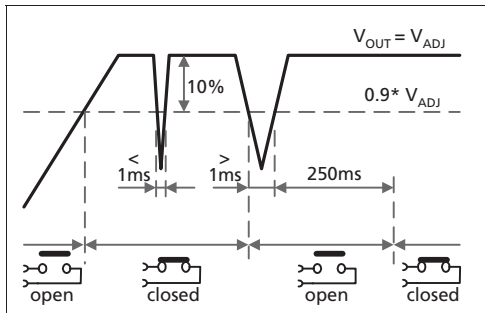

## Shut-down Input

This feature allows a switch-off of the output of the power supply with a signal switch or an external voltage. The shut-down occurs immediately while the turn-on is delayed up to 350 ms. In a shut-down condition, the output voltage is  $< 2V$  and the output power is  $< 0.5 W$ .

The voltage between different minus pole output terminals must be below 1V when units are connected in parallel. In a series operation of multiple power supplies only wiring option “A” with individual signal switches is allowed.

**IMPORTANT** Option C requires a current sink capability of the voltage source. Do not use a blocking diode. - The shut-down function has no safety feature included.

**Figure 16 - Activation of the Shut-down Input**

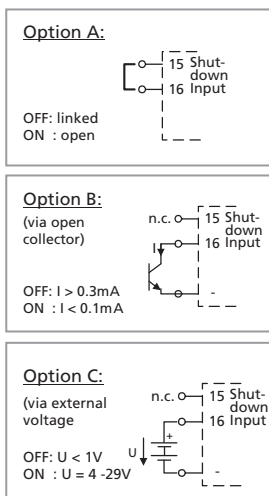

## Remote Control of Output Voltage

The shut-down input can also be used to remotely adjust the output voltage between typically 22V DC and 28V DC. All other functions of shut-down input remain the same.

The control voltage is referenced to the main ground (negative output voltage)

**Figure 17 - Remote Control of the Output Voltage**

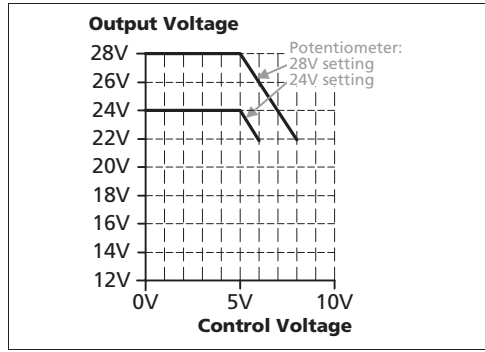

**Figure 18 - Applying the Control Voltage**

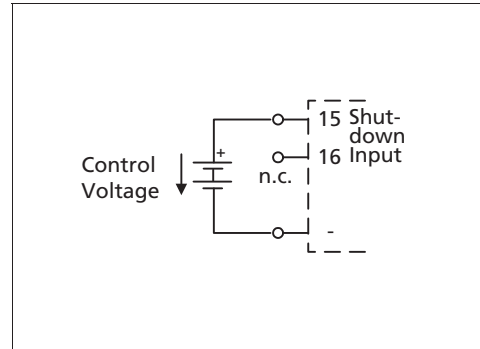

### Instructions

1. Set the unit into "Single Use" mode
2. Set the output voltage adjustment (24...28V) to the maximum desired voltage.
3. Apply a control voltage to reduce the output voltage

## Internal Data Logging

A protected microcontroller inside the power supply acquires and stores operating data during the life of the unit. The data can be downloaded with a small tool and special software by the Rockwell Automation service and repair personnel, even when the unit is non-operational. The data allows for better troubleshooting. Analysis of what happened before a failure can be determined much more accurately.

### Acquired Data

- Family name of unit (1606-XLS), revision of firmware
- Operational hours
- Expired portion of lifetime (combination of temperature and time)
- Maximum ambient temperatures with timestamp (max 47 values)
- Maximal input voltages with timestamp (max 47 values) and type of input voltage (AC or DC)
- Failure report (various internal errors)
- Number and timestamp of input overvoltage transients
- Number and timestamp of over-temperature shut-downs
- Number of turn-on sequences

The data will be acquired with a fixed sampling rate unless the peak detectors do trigger due to an abnormal condition. In such cases, the abnormal condition will be captured. Furthermore, data will be acquired every time shortly before the unit switches off.

## Efficiency and Power Losses

Attribute	100V AC	120V AC	230V AC	Notes
Efficiency, typ	93.2%	93.6%	94.6%	at 24V, 40 A
Average efficiency, typ <sup>(1)</sup>	92.7%	93.0%	93.9%	25% at 10 A, 25% at 20 A, 25% at 30 A. 25% at 40 A
Power losses, typ	3.6 W	3.5 W	3.3 W	with activated shut-down
	13.9 W	13.1 W	13.2 W	at 24V, 0 A (no load)
	36.1 W	34.5 W	30.6 W	at 24V, 20 A (half load)
	70.0 W	65.6 W	54.8 W	at 24V, 40 A (full load)

(1) The average efficiency is an assumption for a typical application where the power supply is loaded with 25% of the nominal load for 25% of the time, 50% of the nominal load for another 25% of the time, 75% of the nominal load for another 25% of the time and with 100% of the nominal load for the rest of the time.

Figure 19 - Efficiency vs. Output Current at 24V, typ

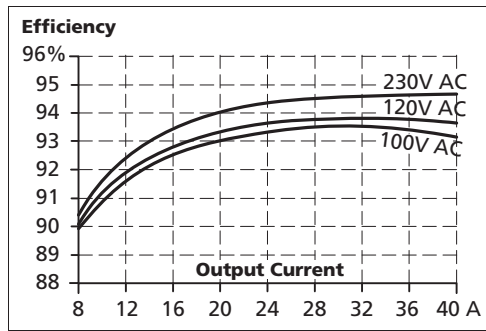

Figure 21 - Power Losses vs. Output Current

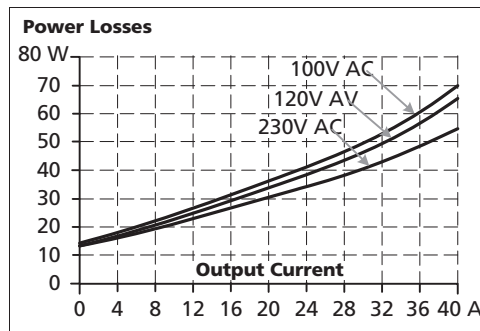

Figure 20 - Efficiency vs. Input Voltage at 24V, 40 A, typ

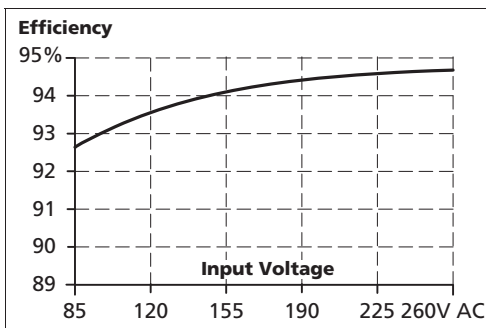
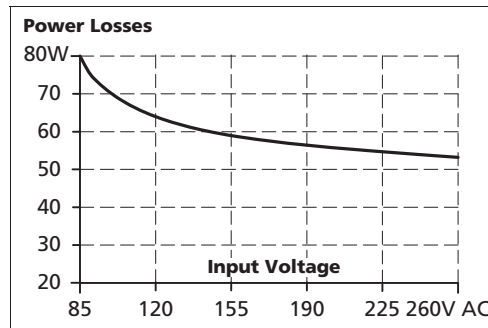

Figure 22 - Power Losses vs. Input Voltage at 24V, 40 A, typ



## Lifetime Expectancy and MTBF

Attribute		AC 100V	AC 120V	AC 230V	Notes
Calculated lifetime expectancy <sup>(1)</sup>		288 000 h	291 000 h	317 000 h	at 24V, 20 A and 25 °C (77 °F)
		102 000 h	103 000 h	112 000 h	at 24V, 20 A and 40 °C (104 °F)
		163 000 h	181 000 h	238 000 h	at 24V, 40 A and 25 °C (77 °F)
		57 000 h	64 000 h	84 000 h	at 24V, 40 A and 40 °C (104 °F)
MTBF <sup>(2)</sup>	SN 29500, IEC 61709	491 000 h	481 000 h	537 000 h	at 24V, 40 A and 25 °C (77 °F)
		274 000 h	269 000 h	300 000 h	at 24V, 40 A and 40 °C (104 °F)
	MIL HDBK 217F Ground Benign	170 000 h	171 000 h	183 000 h	at 24V, 40 A and 25 °C (77 °F); Ground Benign GB25
		126 000 h	127 000 h	137 000 h	at 24V, 40 A and 40 °C (104 °F); Ground Benign GB40
	MIL HDBK 217F Ground Fixed	36 000 h	36 000 h	39 000 h	at 24V, 40 A and 25 °C(77 °F); Ground Fixed GF25
		27 000 h	27 000 h	30 000 h	at 24V, 40 A and 40 °C (104 °F); Ground Fixed GF40

- (1) The calculated lifetime expectancy that is shown in the table indicates the minimum operating hours (service life) and is determined by the lifetime expectancy of the built-in electrolytic capacitors. Lifetime expectancy is specified in operational hours and is calculated according to the capacitor's manufacturer specification. The manufacturer of the electrolytic capacitors only guarantees a maximum life of up to 15 years (131 400 h). Any number exceeding this value is a calculated theoretical lifetime that can be used to compare devices.
- (2) MTBF represents Mean Time Between Failure, which is calculated according to statistical device failures, and indicates reliability of a device. It is the statistical representation of the likelihood of a unit to fail and does not necessarily represent the life of a product. The MTBF figure is a statistical representation of the likelihood of a device to fail. A MTBF figure of, for example, 1 000 000h means that statistically one unit will fail every 100 hours if 10 000 units are installed in the field. However, it cannot be determined if the failed unit has been running for 50 000h or only for 100 h.

## Functional Diagram

Figure 23 - Functional Diagram

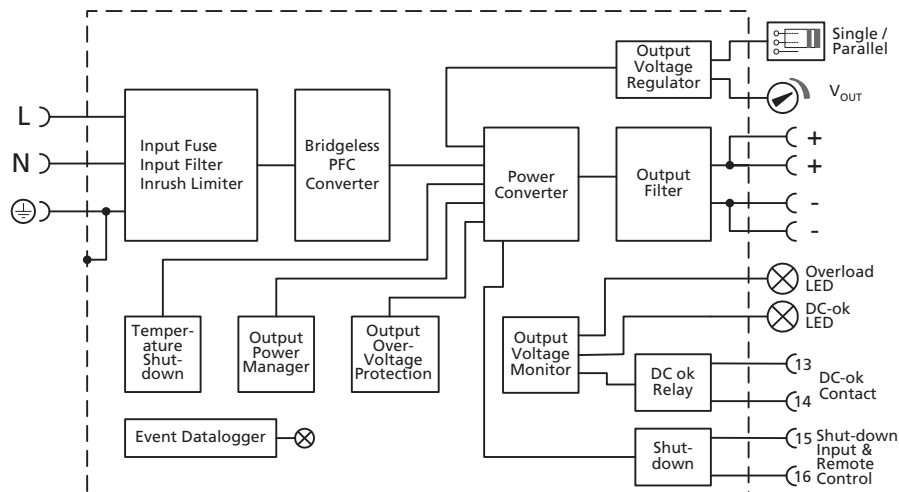

## Terminal and Wiring

The terminals are IP20 Finger safe constructed and suitable for field and factory wiring.

Type	Input	Output	DC-OK, Shut-down
	screw termination	screw termination	spring-clamp termination
Solid wire	0.5-6mm <sup>2</sup>	0.5...16 mm <sup>2</sup>	0.15-1.5mm <sup>2</sup>
Stranded wire	0.5-4mm <sup>2</sup>	0.5...10 mm <sup>2</sup>	0.15-1.5mm <sup>2</sup>
American Wire Gauge	AWG 20-10	AWG 22-8	AWG 26-14
max wire diameter	2.8 mm (including ferrules)	5.2 mm (including ferrules)	1.5 mm (including ferrules)
Wire stripping length	7 mm (0.28 in.)	12 mm / 0.5 inch	7 mm / 0.28 inch
Screwdriver	3.5 mm slotted or cross-head No 2	3.5 mm or 5 mm slotted or cross-head No 2	3 mm slotted (to open the spring)
Recommended tightening torque	1 Nm, 9 lb.in	2.3 Nm, 20.5 lb.in	Not applicable

- Use appropriate copper cables that are designed for minimum operating temperatures of: 60 °C for ambient up to 45 °C and 75 °C for ambient up to 60 °C minimum 90 °C for ambient up to 70 °C minimum.
- Follow national and local installation codes and installation regulations.
- Ensure that all strands of a stranded wire enter the terminal connection.
- Do not use the unit without PE connection.
- Unused terminal compartments should be securely tightened.
- Ferrules are allowed.

## Daisy Chaining

Daisy chaining (jumping from one power supply output to the next) is allowed as long as the average output current through one terminal pin does not exceed 54 A. If the current is higher, use a separate distribution terminal block as shown in [Figure 25](#).

**Figure 24 - Daisy Chaining of Outputs**

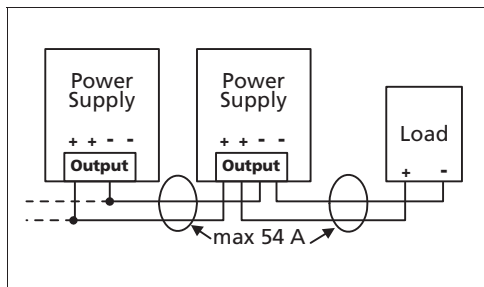

**Figure 25 - Using Distribution Terminals**

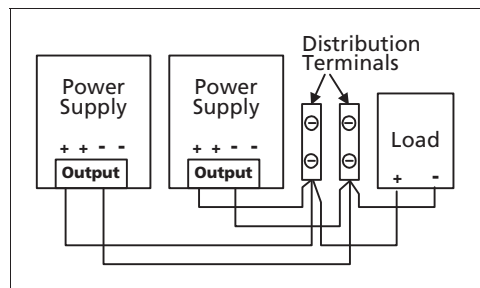

## Front Side and User Elements

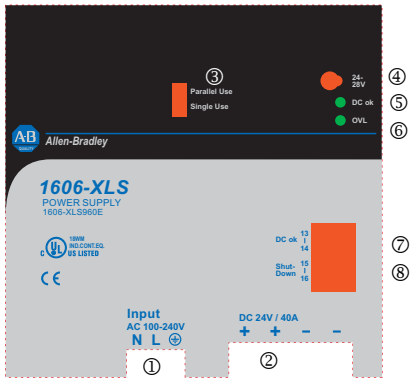

### 1. Input Terminals

(Screw terminals) N, L Line input ...PE (Protective Earth) input

### 2. Output Terminals

(Screw terminals, two pins per pole) + Positive output – Negative (return) output

### 3. “Parallel Use” “Single Use”

Selector Set jumper to “Parallel Use” when power supplies are connected in parallel to increase the output power. To achieve a sharing of the load current between the individual power supplies, the “parallel use” regulates the output voltage in such a manner that the voltage at no load is approx. 4% higher than at nominal load. A missing jumper is equal to a “Single Use” mode.

### 4. Output Voltage

Potentiometer Multi turn potentiometer; Open the flap to set the output voltage. Factory set: 24.1V at full output current, “Single Use” mode.

### 5. DC-OK LED (green)

On, when the voltage on the output terminals is >90% of the adjusted output voltage

### 6. Overload LED (red)

On, when the voltage on the output terminals is <90% of the adjusted output voltage, or if there is a short circuit in the output. - Flashing, when the shut-down has been activated or the unit has switched off due to over-temperature. - Input voltage is required

### 7. DC-OK Relay Contact

The DC-OK relay contact is synchronized with the DC-OK LED. Refer to [DC-OK Relay Contact on page 7](#).

### 8. Shut-down and Remote Control Input

Allows the power supply to be shut down. Can be activated with a switch contact or an external voltage. The remote control input allows adjusting the output voltage between 22V and 28V. Refer to [Shut-down Input on page 8](#) and [Remote Control of Output Voltage on page 9](#).

## Status Indicators

Status Indicator	Overload Status Indicator	DC-OK Status Indicator	DC-OK Contact
Normal mode	OFF	ON	Closed
During BonusPower®	OFF	ON	Closed
Overload (Hiccup mode)	flashing	OFF	Open
Output short circuit	flashing	OFF	Open
Temperature Shut-down	flashing	OFF	Open
Active Shut-down input	flashing	OFF	Open
No input power	OFF	OFF	Open

## EMC

EMC Immunity		According to generic standards: EN 61000-6-1 and EN 61000-6-2		
The 1606-XLS960E is suitable for applications in industrial environment and in residential, commercial, and light industry environment without any restrictions.				
Electrostatic discharge	EN 61000-4-2	contact discharge	8 kV	Criterion A
		air discharge	15 kV	Criterion A
Electromagnetic RF field	EN 61000-4-3	80MHz-2.7GHz	20V/m	Criterion A
Fast transients (Burst)	EN 61000-4-4	input lines	4 kV	Criterion A
		output lines	2 kV	Criterion A
		signal lines (coupling clamp)	2 kV	Criterion A
Surge voltage on input	EN 61000-4-5	L..N	2 kV	Criterion A
		L..PE, N..PE	4 kV	Criterion A
Surge voltage on output	EN 61000-4-5	+ .. -	1 kV	Criterion A
		+ / - .. PE	1 kV	Criterion A
Surge voltage on signal lines	EN 61000-4-5	DC-0K signal.. PE	1 kV	Criterion A
	EN 61000-4-5	Shut-down input.. PE	not relevant due to wire length <sup>(1)</sup>	
Conducted disturbance	EN 61000-4-6	0.15-80MHz	20V	Criterion A
Line voltage dips	EN 61000-4-11	0% of 100V AC	0V AC, 20 ms	Criterion A
		40% of 100V AC	40V AC, 200 ms	Criterion C
		70% of 100V AC	70V AC, 500 ms	Criterion A
		0% of 200V AC	0V AC, 20 ms	Criterion A
		40% of 200V AC	80V AC, 200 ms	Criterion A
		70% of 200V AC	140V AC, 500 ms	Criterion A
Voltage interruptions	EN 61000-4-11	0% of 200V AC (=0V)	5000 ms	Criterion C
Voltage sags	SEMI F47 0706	dips on the input voltage according to SEMI F47 standard		
		80% of 120V AC (96V AC)	1000 ms	Criterion A
		70% of 120V AC (84V AC)	500 ms	Criterion A
		50% of 120V AC (60V AC)	200 ms	Criterion A
Powerful transients	VDE 0160	over entire load range	750V, 1.3 ms	Criterion B <sup>(2)</sup>

(1) Do not use wires longer than 30 m for the shut-down or input or use an additional protection.

(2) Criterion A is fulfilled for output up to 30 A.

Criterion	Description
A	Power supply shows normal operation behavior within the defined limits.
B	Output voltage will dip from 24V to 21V for 5 ms
C	Temporary loss of function is possible. Power supply can shut-down and restarts by itself. No damage or hazards for the power supply will occur.

EMC Emissions	According to generic standards: EN61000-6-3 and EN61000-6-4	
Conducted emissions input line	EN 55011, EN 55022, FCC Part 15, CISPR 11, CISPR 22	Class B
Conducted emission output lines	IEC/CISPR 16-1-2, IEC/CISPR 16-2-1	10 dB higher than average limits for DC power port according to EN 61000-6-3 <sup>(1)</sup>
Radiated emission	EN 55011, EN 55022	Class B
Harmonic input current	EN 61000-3-2	Fulfilled for Class A equipment
Voltage Fluctuations, flicker	EN 61000-3-3	Fulfilled <sup>(2)</sup>

This device complies with FCC part 15 rules

Operation is subjected to following conditions: (1) this device cannot cause harmful interference, and (2) this device must accept any interference received, including interference that can cause undesired operation.

(1) Tested with constant current loads, non pulsing

(2) Restrictions apply for applications in residential, commercial, and light-industrial environments, where local DC power networks according to EN 61000-6-3 are involved. No restrictions for all kinds of industrial applications.

## Switching Frequencies

Switching Frequencies	The power supply has four converters with four different switching frequencies included. One is nearly constant. The others are input voltage and load dependent.	
Switching frequency 1	105 kHz	Resonant converter, nearly constant
Switching frequency 2	1...150 kHz	Boost converter, input voltage, and load dependent
Switching frequency 3	1...100 kHz	PFC converter, input voltage, and load dependent
Switching frequency 4	25...45 kHz	Aux. converter, input voltage, and load dependent

## Environment

Attribute	Value	Notes
Operational temperature <sup>(1)</sup>	-25...+70 °C (-13...+158 °F)	reduce output power according to <a href="#">Figure 26</a>
Storage temperature	-40...+85°C (-40...+185 °F)	for storage and transportation
Output de-rating	24 W/°C	60...70°C (140...158 °F)
Humidity <sup>(2)</sup>	5...95% r.H.	IEC 60068-2-30
Vibration sinusoidal	2...17.8 Hz: ±1.6 mm; 17.8...500 Hz: 1 g <sup>(3)</sup> 2 hours / axis	IEC 60068-2-6
Shock	15 g 6 ms, 10 g 11 ms <sup>(4)</sup> 3 bumps / direction, 18 bumps in total	IEC 60068-2-27
Altitude	0...2000 m (0...6560 ft)	without any restrictions
	2000...6000 m (6560...20000 ft)	reduce output power or ambient temperature, see <a href="#">Figure 27</a> IEC 62103, EN 50178, overvoltage category II
Altitude de-rating	60 W/1000 m or 5°C/1000 m	> 2000 m (6500 ft), see <a href="#">Figure 27</a> .
Over-voltage category	III	IEC 62103, EN 50178, altitudes up to 2000 m
	II	altitudes 2000...6000 m
Degree of pollution	2	IEC 62103, EN 50178, not conductive
LABS compatibility	The unit does not release any silicone or other LABS-critical substances and is suitable for use in paint shops.	

(1) Operational temperature is the same as ambient or surrounding temperature and is defined as the air temperature 2 cm below the unit.

(2) Do not energize when condensation is present.

(3) Higher levels that are allowed when using wall mounting bracket.

(4) Higher levels that are allowed when using wall mounting bracket.

**Figure 26 - Output Current vs. Ambient Temperature**

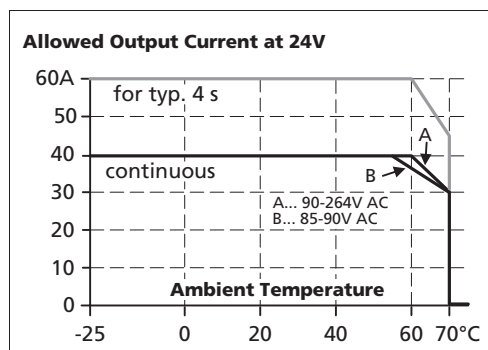

**Figure 27 - Output Current vs. Altitude**

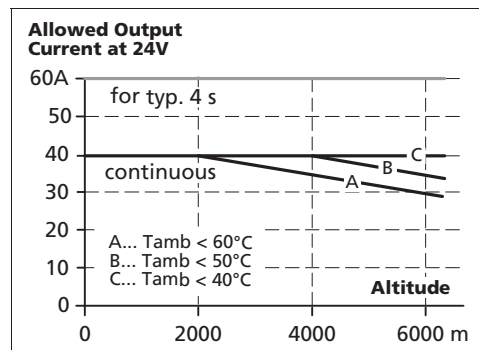

## Protection Features

Feature	Description	
Output protection	Electronically protected against overload, no-load, and short-circuits <sup>(1)</sup>	
Output over-voltage protection	typ 30V DC max 32V DC	In case of an internal power supply defect, a redundant circuit limits the maximum output voltage. The output shuts down and automatically attempts to restart.
Degree of protection	IP 20	EN/IEC 60529 Caution: For use in a controlled environment according to CSA 22.2 No 107.1-01.
Penetration protection	> 5 mm	for example, screws, small parts
Over-temperature protection	yes	Output shut-down with automatic restart
Input transient protection	MOV (Metal Oxide Varistor)	
Internal input fuse	included	not user replaceable

(1) In case of protection event, audible noise can occur.

## Safety Features

Attribute	Value/Description	
Input / output separation <sup>(1)</sup>	SELV	IEC/EN 60950-1
	PELV	IEC/EN 60204-1, EN 50178, IEC 62103, IEC 60364-4-41
	double or reinforced insulation	
Class of protection	I	PE (Protective Earth) connection required
Isolation resistance	> 5MΩ	input to output, 500V DC
PE resistance	< 0.1 Ω	
Touch current (leakage current)	typ 0.39 mA / 1.0 mA	100V AC, 50 Hz, TN-,TT-mains / IT-mains
	typ 0.56 mA / 1.43 mA	120V AC, 60 Hz, TN-,TT-mains / IT-mains
	typ 0.90 mA / 2.25 mA	230V AC, 50 Hz, TN-,TT-mains / IT-mains
	max 0.50 mA / 1.21 mA	110V AC, 50 Hz, TN-,TT-mains / IT-mains
	max 0.71 mA / 1.73 mA	132V AC, 60 Hz, TN-,TT-mains / IT-mains
	max 1.18 mA / 2.82 mA	264V AC, 50 Hz, TN-,TT-mains / IT-mains

(1) Double or reinforced insulation

## Dielectric Strength

The output voltage is floating and has no ohmic connection to the ground. Type and factory tests are conducted by the manufacturer. Field tests may be conducted in the field using the appropriate test equipment that applies the voltage with a slow ramp (2 s up and 2 s down). Connect all input-terminals together and all output poles before conducting the test. When testing, set the cut-off current settings to the value in the table below.

**Figure 28 - Dielectric Strength**

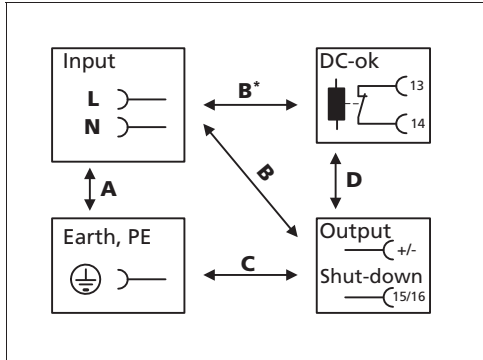

\* When testing input to DC-OK ensure that the max. voltage between DC-OK and the output is not exceeded (column D). We recommend connecting DC-OK pins and the output pins together when performing the test.

Attribute		A	B	C	D
Type test	60 s	2500V AC	3000V AC	500V AC	500V AC
Factory test	5 s	2500V AC	2500V AC	500V AC	500V AC
Field test	5 s	2000V AC	2000V AC	500V AC	500V AC
Cut-off current setting		> 20 mA	> 20 mA	> 40 mA	> 1 mA

To fulfill the PELV requirements according to EN60204-1 § 6.4.1, we recommend that either the + pole, the – pole or any other part of the output circuit shall be connected to the protective earth system. This helps to avoid situations in which a load starts unexpectedly or cannot be switched off when unnoticed earth faults occur.

## Standards and Certifications

EC Declaration of Conformity	The CE mark indicates conformance with the - EMC directive 2014/30/EU , Low-voltage directive (LVD) 2014/35/EU RoHS directive 2011/65/EU.
UL 508	Listed for use as Industrial Control Equipment; U.S.A. (UL 508) and Canada (C22.2 No. 107-1); E-File: E56639
UL 60950-1	Recognized for use as Information Technology Equipment, Level 5; U.S.A. (UL 60950-1) and Canada (C22.2 No. 60950-1); E-File: E168663. Applicable for altitudes up to 2000 m.
ANSI / ISA 12.12.01-Class I Div 2	Certified for use in Hazardous Location Class I Div 2 T4 Groups A,B,C,D systems; U.S.A. (ANSI / ISA 12.12.01) and Canada (C22.2 No. 213)
EN 60079-0, EN 60079-15	Approval for use in hazardous locations Zone 2 Category 3G. Number of ATEX certificate: EPS 14 ATEX 1 638 X The power supply must be built in in an IP54 enclosure.
IEC 60079-0, IEC 60079-15	Suitable for use in Class 1 Zone 2 Groups IIa, IIb and IIc locations. Number of IECEx certificate: IECEx EPS 14.0081X

## Approximate Dimensions

Attribute	Value/Description
Weight	1900 g (4.2 lb)
Din-Rail	Use 35mm DIN-rails according to EN 60715 or EN 50022 with a height of 7.5 or 15 mm. The DIN-rail height must be added to the unit depth (127 mm) to calculate the total required installation depth.
Installation Clearance	See <a href="#">Installation Requirements</a> .

Figure 29 - Front View

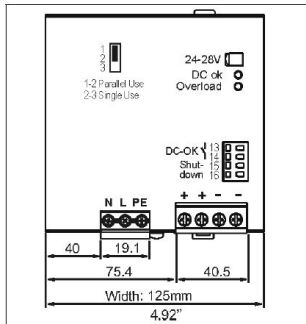
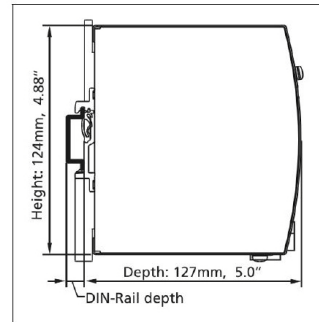

Figure 30 - Side View



## Intended Use

- This device is designed for installation in an enclosure and is intended for the general use such as in industrial control, office, communication, and instrumentation equipment.
- Do not use this power supply in equipment, where malfunction may cause severe personal injury or threaten human life.
- This device is designed for use in hazardous, non-hazardous, ordinary, or unclassified locations.

## Installation Requirements

- This device may only be installed and put into operation by qualified personnel.
- This device does not contain serviceable parts. The tripping of an internal fuse is caused by an internal defect.
- If damage or malfunction should occur during installation or operation, immediately turn power off and send unit to the factory for inspection.
- Mount the unit on a DIN-rail so that the output and input terminals are on the bottom of the unit. For other mounting orientations see derating requirements in this document. Refer to [Mounting Orientations on page 26](#).
- This device is designed for convection cooling and does not require an external fan. Do not obstruct airflow and do not cover ventilation grid (for example, cable conduits) by more than 15%.
- Keep the following installation clearances: 40 mm on top, 20 mm on the bottom, 5 mm on the left and right sides are recommended when the device is loaded permanently with more than 50% of the rated power. Increase this clearance to 15 mm in case the adjacent device is a heat source (for example, another power supply).
- A disconnecting means shall be provided for the output of the power supplies when used in applications according to CSA C22.2 No 107.1-01.



**WARNING:** Risk of electrical shock, fire, personal injury, or death.

- Do not use the power supply without proper grounding (Protective Earth).
- Use the terminal on the input block for earth connection and not one of the screws on the housing.
- Turn power off before working on the device. Protect against inadvertent repowering.
- Make sure that the wiring is correct by following all local and national codes.
- Do not modify or repair the unit.
- Do not open the unit as high voltages are present inside.
- Use caution to prevent any foreign objects from entering the housing.
- Do not use in wet locations or in areas where moisture or condensation can be expected.
- Do not touch during power-on, and immediately after power-off. Hot surfaces may cause burns.



**WARNING:** Notes for use in hazardous location areas:

- The power supply is suitable for use in Class I Division 2 Groups A, B, C, D locations and for use in Group II Category 3 (Zone 2) environments and are evaluated according to EN 60079-0:2012 and EN 60079-15:2010.

**WARNING:** WARNING EXPLOSION HAZARDS

- Substitution of components may impair suitability for this environment. Do not disconnect the unit or operate the voltage adjustment or S/P jumper unless power has been switched off or the area is known to be non-hazardous.
- A suitable enclosure must be provided for the end product that has a minimum protection of IP54 and fulfils the requirements of the EN 60079-15:2010.

## Accessories

### Wall Mounting Bracket - Catalog Number 1606-XLC

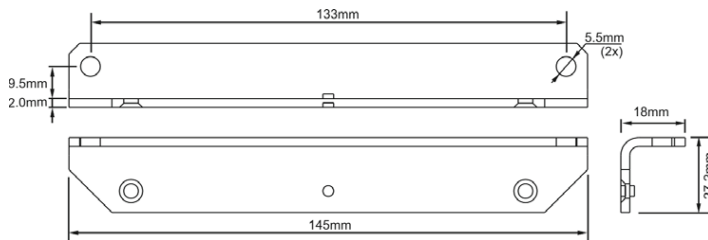

### Buffer Module

This buffer unit is a supplementary device for DC 24V power supplies. It delivers power to bridge typical mains failures or extends the hold-up time after turn-off of the AC power. In times when the power supply provides sufficient voltages, the buffer unit stores energy in integrated electrolytic capacitors. In case of mains voltage fault, this energy is released again in a regulated process. One buffer module can deliver 20 A. To buffer the full output current of 40 A, two buffer modules are needed in parallel.

The buffer unit does not require any control wiring. It can be added in parallel to the load circuit at any given point. Buffer units can be added in parallel to increase the output ampacity or the hold-up time.

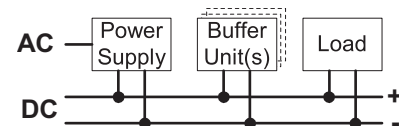

## Redundancy Module

The cat. no. 1606-XLSRED80HE is equipped with two input channels (40 A each), which are individually decoupled by utilizing mosfet technology. The output current can go as high as 80 A. Using mosfets instead of diodes reduces the heat generation and the voltage drop between input and output. The 1606-XLSRED80HE does not require an additional auxiliary voltage and is self-powered even if there is a short circuit across the output.

Due to the low-power losses, the unit is slender and only requires 46 mm width on the DIN-rail.

## Redundancy Module

The 1606-XLSREDS40HE is a 40 A single channel redundancy module, which is equipped with a plug connector on the output. The plug connector allows replacing the power supply or the redundancy module while the system is running. The plug connector avoids that the output wires can touch and short the load circuit.

The 1606-XLSREDS40HE is slender and only requires 46 mm width on the DIN-rail. It also utilizes mosfet technology instead of diodes for low heat generation and a minimal voltage drop between input and output. It does not require an additional auxiliary voltage and is self-powered even if there is a short circuit across the output

**Figure 31 - Typical 1+1 Redundant configuration for 40 A with a dual redundancy module**

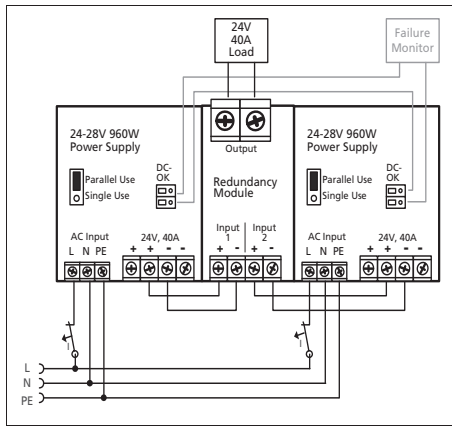

**Figure 32 - Typical N+1 or 1+1 Redundant configuration for 40 A with multiple redundancy modules**

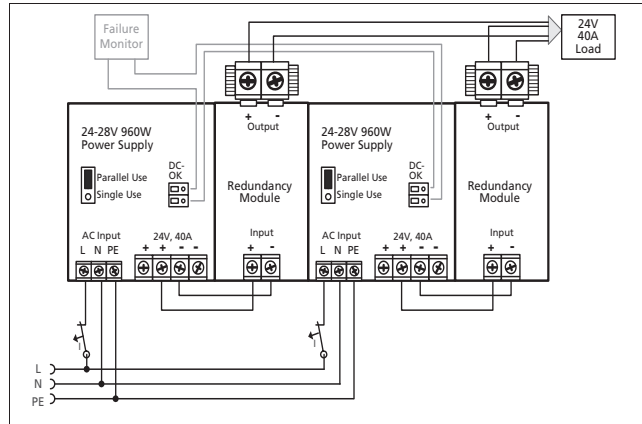

## Application Notes

### Repetitive Pulse Loading

Typically, a load current is not constant and varies over time. This power supply is designed to support loads with a higher short-term power demand (=BonusPower®). The short-term duration is hardware that is controlled by an output power manager and is available on a repeated basis. If the BonusPower® load lasts longer than the hardware controller allows it, the output voltage will dip and the next BonusPower® is available after the BonusPower® recovery time has elapsed.

To avoid this, the following rules must be met:

- The power demand of the pulse must be below 150% of the nominal output power.
- The duration of the pulse power must be shorter than the allowed BonusPower® time. (see output section)
- The average (R.M.S.) output current must be below the specified continuous output current. If the R.M.S. current is higher, the unit will respond with a thermal shut-down after a period of time. Use the maximum duty cycle curve ([Figure 34 on page 21](#)) to check if the average output current is below the nominal current.
- The duty cycle must be below 0.75.

Figure 33 - Repetitive Pulse Loads Definitions

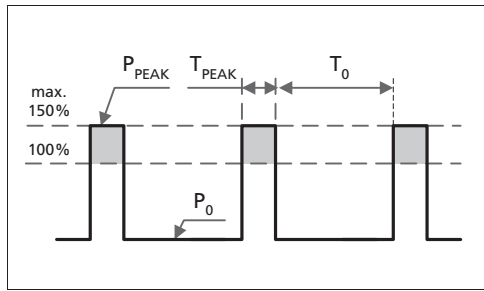

- $P_0$  Base load (W)
- $P_{PEAK}$  Pulse load (above 100%)
- $T_0$  Duration between pulses (s)
- $T_{PEAK}$  Pulse duration (s)

Figure 34 - Max Duty Cycle Curve

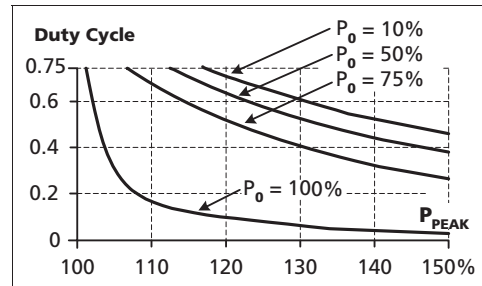

$$\text{DutyCycle} = \frac{T_{peak}}{T_{peak} + T_0}$$

$$T_0 = \frac{T_{peak} - (\text{DutyCycle} \times T_{peak})}{\text{DutyCycle}}$$

**EXAMPLE** A load is powered continuously with 480 W (= 50% of the rated output load). From time to time a peak power of 1440 W (= 150% of the rated output load) is needed for 1 second.

The question is: How often can this pulse be supplied without overloading the power supply?

- Make a vertical line at  $P_{PEAK} = 150\%$  and a horizontal line where the vertical line crosses the  $P_0 = 50\%$  curve. Read the max duty cycle from the duty cycle-axis (= 0.37)
- Calculate the required pause (base load) length  $T_0$ :
- Result: The required pause length = 1.7 s
- max repetition rate = pulse + pause length = **2.7 s**

$$T_0 = \frac{T_{peak} - (\text{DutyCycle} \times T_{peak})}{\text{DutyCycle}} = \frac{1s - (0.37 \times 1s)}{0.37} = \mathbf{1.7s}$$

**More examples for Pulse Load Compatibility**

$P_{PEAK}$	$P_0$	$T_{PEAK}$	$T_0$
1440 W	960 W	1 s	>25 s
1440 W	0 W	1 s	>1.3 s
1200 W	480 W	1 s	>0.75 s

$P_{PEAK}$	$P_0$	$T_{PEAK}$	$T_0$
1440 W	480 W	0.1 s	>0.16 s
1440 W	480 W	1 s	>1.6 s
1440 W	480 W	3 s	>4.9 s

**Peak Current Capability**

The power supply can deliver peak currents (up to several milliseconds) which are higher than the specified short-term currents.

This helps to start current demanding loads. Solenoids, contactors, and pneumatic modules often have a steady state coil and a pick-up coil. The inrush current demand of the pick-up coil is several times higher than the steady-state current and usually exceeds the nominal output current (including the BonusPower®). The same situation applies when starting a capacitive load.

The peak current capability also ensures the safe operation of subsequent circuit breakers of load circuits. The load branches are often individually protected with circuit breakers or fuses. If there is a short or an overload in one branch circuit, the fuse or circuit breaker need a certain amount of over-current to open in a timely manner. This avoids voltage loss in adjacent circuits.

The extra current (peak current) is supplied by the power converter and the built-in large sized output capacitors of the power supply. The capacitors get discharged during such an event, which causes a voltage dip on the output. The following two examples show typical voltage dips:

**Figure 35 - Peak Load with 2x the Nominal Current for 50 ms, typ**

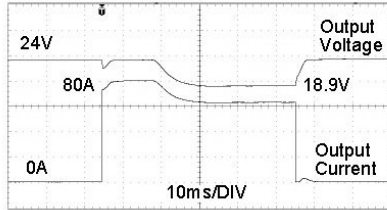

80 A Peak Load Resistive for 50 ms  
Output Voltage dips from 24V to 18.9V

**Figure 36 - Peak Load with 5x the Nominal Current for 5 ms, typ**

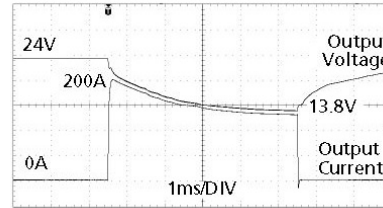

200 A Peak Load Resistive for 5 ms  
Output Voltage dips from 24V to 13.8V

Peak current voltage dips	typ	from 24V... 18.9V	at 80 A for 50 ms, resistive load
	typ	from 24V... 15.9V	at 200 A for 2 ms, resistive load
	typ	from 24V... 13.8V	at 200 A for 5 ms, resistive load

### External Input Protection

The unit is tested and approved for branch circuits up to 30 A (U.S.A.) and 32 A (IEC). An external protection is only required if the supplying branch has an ampacity greater than this. Check also local codes and local requirements. In some countries local regulations might apply.

If an external fuse is necessary or utilized, minimum requirements need to be considered to avoid nuisance tripping of the circuit breaker. A minimum value of 16 A B- or C-Characteristic breaker should be chosen, when the unit is used at AC100 and AC120V mains voltages (including AC 230V). If the unit is used only at AC 230V mains, a 10 A, B-, or C-Characteristic breaker is sufficient.

### Charging of Batteries

The power supply can be used to charge lead-acid or maintenance free batteries. (Two 12V batteries in series)

Instructions for charging batteries:

1. Set output voltage (measured at no load and at the battery end of the cable) precisely to the end-of-charge voltage.

End-of-charge voltage	27.8V	27.5V	27.15V	26.8V
Battery temperature	10 °C	20 °C	30 °C	40 °C

2. Use a 50 A or 63 A circuit breaker (or blocking diode) between the power supply and the battery.
3. Ensure that the output current of the power supply is below the allowed charging current of the battery.
4. Use only matched batteries when putting 12V types in series.
5. The return current to the power supply (battery discharge current) is typ 35 mA when the power supply is switched off (except in case a blocking diode is utilized).

### Output Circuit Breakers

Standard miniature circuit breakers (MCBs or UL1077 circuit breakers) are commonly used for AC-supply systems and may also be used on DC branches.

MCBs are designed to protect wires and circuits. If the ampere value and the characteristics of the MCB are adapted to the wire size that is used, the wiring is considered as thermally safe regardless of whether the MCB opens or not.

To avoid voltage dips and under-voltage situations in adjacent 24V branches that are supplied by the same source, a fast (magnetic) tripping of the MCB is desired. A quick shutdown within 10 ms is necessary corresponding roughly to the ride-through time of PLCs. This requires power supplies

with high current reserves and large output capacitors. Furthermore, the impedance of the faulty branch must be sufficiently small in order for the current to actually flow. The best current reserve in the power supply does not help if Ohm's law does not permit current flow. The following table has typical test results showing which B- and C-Characteristic MCBs magnetically trip depending on the wire cross section and wire length.

**Figure 37 - Test Circuit**

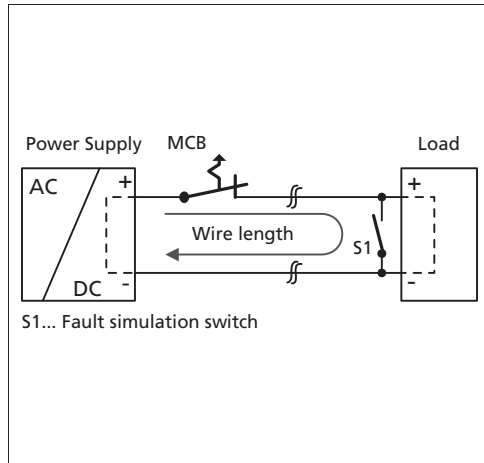

**Maximum Wire Length<sup>(1)</sup> for Fast (magnetic) Tripping**

	0.75 mm <sup>2</sup>	1.0 mm <sup>2</sup>	1.5 mm <sup>2</sup>	2.5 mm <sup>2</sup>
C-2A	29 m	38 m	54 m	86 m
C-3A	27 m	34 m	48 m	78 m
C-4A	19 m	26 m	38 m	58 m
C-6A	10 m	15 m	21 m	34 m
C-8A	8 m	12 m	18 m	28 m
C-10A	7 m	11 m	16 m	26 m
C-13A	4 m	6 m	8 m	13 m
B-6A	19 m	25 m	35 m	55 m
B-10A	11 m	17 m	24 m	40 m
B-13A	10 m	13 m	21 m	29 m
B-16A	7 m	11 m	15 m	24 m

### Parallel Use to Increase Output Power

Power supplies from the same series (1606-XLS) can be paralleled to increase the output power. The output voltage shall be adjusted to the same value ( $\pm 100$  mV) in "Single use" mode with the same load conditions on all units, or the units can be left with the factory settings. After the adjustments, the jumper on the front of the unit shall be moved from "Single use" to "Parallel use", to achieve load sharing. The "Parallel use" mode regulates the output voltage in such a manner that the voltage at no load is approx. 4% higher than at nominal load. If no jumper is plugged in, the unit is in "Single use" mode. Factory setting is also "Single use" mode.

If more than three units are connected in parallel, a fuse or circuit breaker with a rating of 50 A or 63 A is required on each output. Alternatively, a diode or redundancy module can also be utilized.

Energize all units simultaneously to avoid the overload HiccupPLUS mode. It also might be necessary to cycle the input power (turn-off for at least five seconds), if the output was in HiccupPLUS mode due to overload or short circuits and the required output current is higher than the current of one unit.

Keep an installation clearance of 15 mm (left / right) between two power supplies and avoid installing the power supplies on top of each other. Do not use power supplies in parallel in mounting orientations other than the standard mounting orientation (terminals on the bottom of the unit) or in any other condition where a derating of the output current is required (for example altitude, above 60 °C, ...).

Pay attention that leakage current, EMI, inrush current, harmonics will increase when using multiple power supplies.

### Parallel Use for Redundancy

Power supplies can be paralleled for redundancy to gain higher system availability. Redundant systems require a certain amount of extra power to support the load in case one power supply unit fails. The simplest way is to put two power supplies in parallel. This is called a 1+1 redundancy. In case one power supply unit fails, the other one is automatically able to support the load current without any interruption. Redundant systems for a higher power demand are usually built in a N+1 method. For example, five power supplies, each rated for 40 A are paralleled to build a 160 A

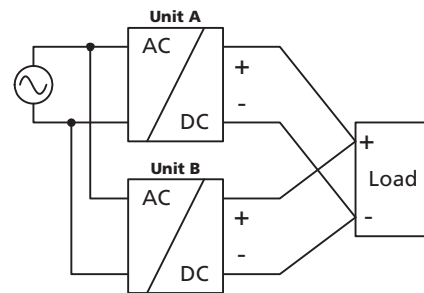

(1) Consider twice the distance to the load (or cable length) when calculating the total wire length (+ and - wire).

redundant system. For N+1 redundancy the same restrictions apply as for increasing the output power, see also [Parallel Use to Increase Output Power on page 23](#).

---

**IMPORTANT** This simple way to build a redundant system does not cover failures such as an internal short circuit in the secondary side of the power supply. In such a case, the defective unit becomes a load for the other power supplies and the output voltage cannot be maintained any more. This can be avoided by utilizing redundancy modules, which have decoupling devices (diodes or mosfets) included. Further information and wiring configurations can be found in [Redundancy Module on page 20](#).

---

#### Recommendations for building redundant power systems:

- Use separate input fuses for each power supply. A separate source for each supply when possible increases the reliability of the redundant system.
- Set the power supply into “Parallel Use” mode.
- Monitor the individual power supply units. Therefore, use the DC-OK relay contact of the power supply.
- It is desirable to set the output voltages of all units to the same value ( $\pm 100$  mV) or leave it at the factory setting.

#### Series Operation

Power supplies of the same type can be connected in series for higher output voltages. It is possible to connect as many units in series as needed, providing the sum of the output voltage does not exceed 150V DC. Voltages with a potential above 60V DC are not SELV any more and can be dangerous. Such voltages must be installed with a protection against touching.

Earthing of the output is required when the sum of the output voltage is above 60V DC.

Avoid return voltage (for example, from a decelerating motor or battery) which is applied to the output terminals.

Keep an installation clearance of 15 mm (left/right) between two power supplies and avoid installing the power supplies on top of each other. Do not use power supplies in series in mounting orientations other than the standard mounting orientation (terminals on the bottom of the unit).

Pay attention that leakage current, EMI, inrush current, harmonics will increase when using multiple power supplies.

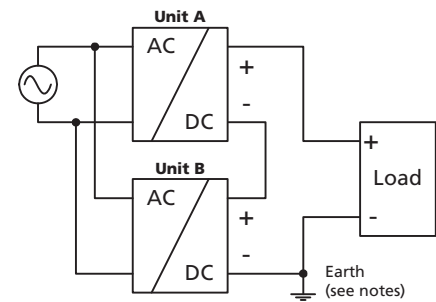

#### Inductive and Capacitive Loads

The unit is designed to supply any kind of loads, including capacitive and inductive loads. If extreme large capacitors, such as EDLCs (electric double layer capacitors or “UltraCaps”) with a capacitance  $> 2.5F$  are connected to the output, the unit might charge the capacitor in the HiccupPLUS mode (see [Output on page 5](#)).

#### Back Feeding Loads

Loads such as decelerating motors and inductors can feed voltage back to the power supply. This feature is also called return voltage immunity or resistance against Back- E.M.F. (Electro Magnetic Force).

This power supply is resistant and does not show malfunctioning when a load feeds back voltage to the power supply. It does not matter whether the power supply is on or off.

The maximum allowed feed-back-voltage is 35V DC. The absorbing energy can be calculated according to the built-in large sized output capacitor that is specified in [Output on page 5](#)

## Operation on Two Phases

The power supply can also be used on two-phases of a three-phase-system. Such a phase to phase connection is allowed as long as the supplying voltage is below  $240V + 10\%$ .

## Enclosure

When the power supply is installed in a tightly sealed enclosure, the temperature inside the enclosure will be higher than outside. In such situations, the inside temperature defines the ambient temperature for the power supply.

The following measurement results can be used as a reference to estimate the temperature rise inside the enclosure.

The power supply is placed in the middle of the box, no other heat producing items are inside the box

Enclosure	Rittal typ IP66 Box PK 9522 100, plastic, 254 x 180 x 165 mm
Load	24V, 32 A; (=80%) load is placed outside the box
Input	230V AC
Temperature inside enclosure	68.6 °C (in the middle of the right side of the power supply with a distance of 2 cm)
Temperature outside enclosure	24.3 °C
Temperature rise	44.3 K

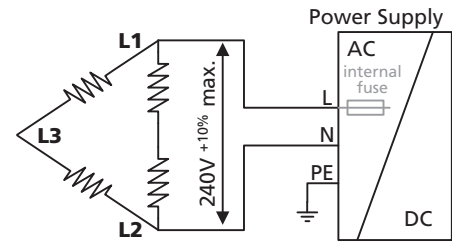

### Mounting Orientations

Mounting orientations other than all terminals on the bottom require a reduction in continuous output power or a limitation in the maximum allowed ambient temperature. The amount of reduction influences the lifetime expectancy of the power supply. Therefore, two different derating curves for continuous operation can be found:

Curve A1	Recommended output current.
Curve A2	Max allowed output current (results in approximately half the lifetime expectancy of A1).

**Figure 38 - Mounting Orientation A (Standard)**

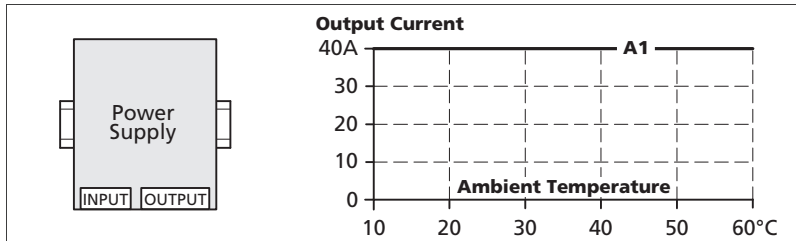

**Figure 39 - Mounting Orientation B (Upside Down)**

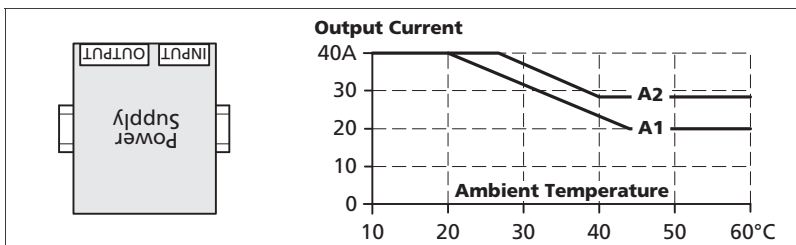

**Figure 40 - Mounting Orientation C (Table-top Mounting)**

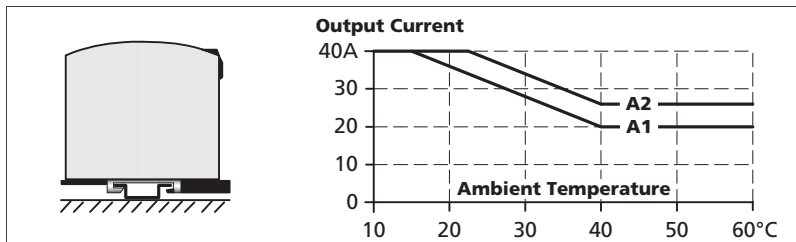

**Figure 41 - Mounting Orientation D (Horizontal cw)**

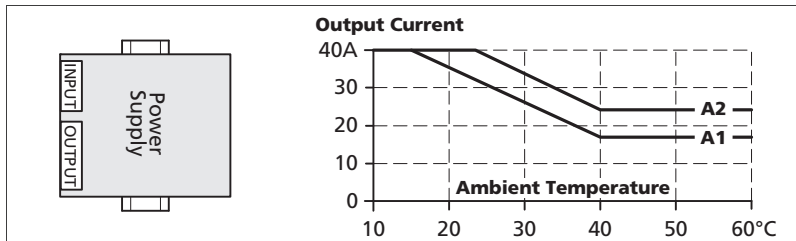

**Figure 42 - Mounting Orientation E (Horizontal ccw)**

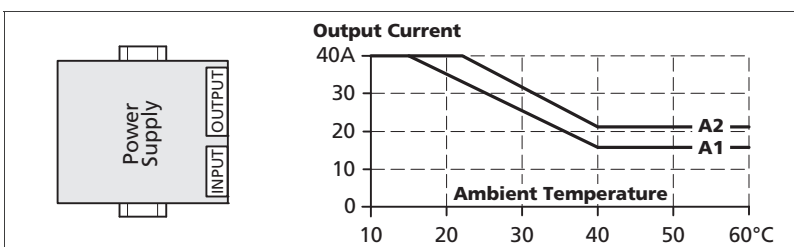

## Additional Resources

These documents contain additional information concerning related products from Rockwell Automation.

Resource	Description
Bulletin 1606 Switched Mode Power Supplies Technical Data, publication <a href="#">1606-TD002</a>	Provides detailed specifications of the 1606 Switched Mode power supply line.
Operational Cost Saving Opportunities for System Designers in Control Power White Paper, publication <a href="#">1606-WP001</a>	White paper outlining the operational cost savings of using an efficient Switched Mode Power Supply to reduce the excess panel heat, space requirements and transformer size.
Industrial Automation Wiring and Grounding Guidelines, publication <a href="#">1770-4.1</a>	Provides general guidelines for installing a Rockwell Automation industrial system.
Product Certifications website, <a href="http://www.rockwellautomation.com/global/certification/overview.page">http://www.rockwellautomation.com/global/certification/overview.page</a>	Provides declarations of conformity, certificates, and other certification details.

You can view or download publications at <http://www.rockwellautomation.com/global/literature-library/overview.page>. To order paper copies of technical documentation, contact your local Allen-Bradley distributor or Rockwell Automation sales representative.

## Rockwell Automation Support

Use the following resources to access support information.

<b>Technical Support Center</b>	Knowledgebase Articles, How-to Videos, FAQs, Chat, User Forums, and Product Notification Updates.	<a href="http://www.rockwellautomation.com/knowledgebase">www.rockwellautomation.com/knowledgebase</a>
<b>Local Technical Support Phone Numbers</b>	Locate the phone number for your country.	<a href="http://www.rockwellautomation.com/global/support/get-support-now.page">www.rockwellautomation.com/global/support/get-support-now.page</a>
<b>Direct Dial Codes</b>	Find the Direct Dial Code for your product. Use the code to route your call directly to a technical support engineer.	<a href="http://www.rockwellautomation.com/global/support/direct-dial.page">www.rockwellautomation.com/global/support/direct-dial.page</a>
<b>Literature Library</b>	Installation Instructions, Manuals, Brochures, and Technical Data.	<a href="http://www.rockwellautomation.com/literature">www.rockwellautomation.com/literature</a>
<b>Product Compatibility and Download Center (PCDC)</b>	Get help determining how products interact, check features and capabilities, and find associated firmware.	<a href="http://www.rockwellautomation.com/global/support/pcdc.page">www.rockwellautomation.com/global/support/pcdc.page</a>

## Documentation Feedback

Your comments will help us serve your documentation needs better. If you have any suggestions on how to improve this document, complete the How Are We Doing? form at [http://literature.rockwellautomation.com/idc/groups/literature/documents/du/ra-du002\\_-en-e.pdf](http://literature.rockwellautomation.com/idc/groups/literature/documents/du/ra-du002_-en-e.pdf).

Rockwell Automation maintains current product environmental information on its website at <http://www.rockwellautomation.com/rockwellautomation/about-us/sustainability-ethics/product-environmental-compliance.page>.

Allen-Bradley, Rockwell Software, Rockwell Automation, and LISTEN. THINK. SOLVE are trademarks of Rockwell Automation, Inc. Trademarks not belonging to Rockwell Automation are property of their respective companies.

Rockwell Otomasyon Ticaret A.Ş., Kar Plaza İş Merkezi E Blok Kat:6 34752 İçerenköy, İstanbul, Tel: +90 (216) 5698400

**[www.rockwellautomation.com](http://www.rockwellautomation.com)**

### Power, Control and Information Solutions Headquarters

Americas: Rockwell Automation, 1201 South Second Street, Milwaukee, WI 53204-2496 USA, Tel: (1) 414.382.2000, Fax: (1) 414.382.4444  
Europe/Middle East/Africa: Rockwell Automation NV, Pegasus Park, De Kleetlaan 12a, 1831 Diegem, Belgium, Tel: (32) 2 663 0600, Fax: (32) 2 663 0640  
Asia Pacific: Rockwell Automation, Level 14, Core F, Cyberport 3, 100 Cyberport Road, Hong Kong, Tel: (852) 2887 4788, Fax: (852) 2508 1846