

XM-942 Master Relay Terminal Base

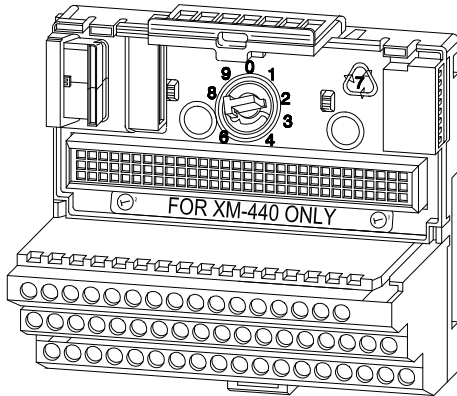

Catalog Number 1440-TB-C

Installation Instructions



For information about	See page
Important User Information	2
Safety Approvals	4
Power Requirements	6
Interconnect Limit	7
Wiring Requirements	7
Grounding Requirements	8
Mounting on the DIN Rail	12
Wiring	15
Agency Certification	17
Specifications	18

Important User Information

Solid state equipment has operational characteristics differing from those of electromechanical equipment. Safety Guidelines for the Application, Installation and Maintenance of Solid State Controls (Publication SGI-1.1 available from your local Rockwell Automation sales office or online at <http://literature.rockwellautomation.com>) describes some important differences between solid state equipment and hard-wired electromechanical devices. Because of this difference, and also because of the wide variety of uses for solid state equipment, all persons responsible for applying this equipment must satisfy themselves that each intended application of this equipment is acceptable.





In no event will Rockwell Automation, Inc. be responsible or liable for indirect or consequential damages resulting from the use or application of this equipment.

The examples and diagrams in this manual are included solely for illustrative purposes. Because of the many variables and requirements associated with any particular installation, Rockwell Automation, Inc. cannot assume responsibility or liability for actual use based on the examples and diagrams.

No patent liability is assumed by Rockwell Automation, Inc. with respect to use of information, circuits, equipment, or software described in this manual.

Reproduction of the contents of this manual, in whole or in part, without written permission of Rockwell Automation, Inc., is prohibited.

Throughout this manual, when necessary, we use notes to make you aware of safety considerations.

WARNING 	Identifies information about practices or circumstances that can cause an explosion in a hazardous environment, which may lead to personal injury or death, property damage, or economic loss.
IMPORTANT	Identifies information that is critical for successful application and understanding of the product.
ATTENTION 	Identifies information about practices or circumstances that can lead to personal injury or death, property damage, or economic loss. Attentions help you identify a hazard, avoid a hazard and recognize the consequences.
SHOCK HAZARD 	Labels may be on or inside the equipment (for example, drive or motor) to alert people that dangerous voltage may be present.
BURN HAZARD 	Labels may be on or inside the equipment (for example, drive or motor) to alert people that surfaces may reach dangerous temperatures.

ATTENTION**Environment and Enclosure**

This equipment is supplied as “open type” equipment. It must be mounted within an enclosure that is suitably designed for those specific environmental conditions that will be present, and appropriately designed to prevent personal injury resulting from accessibility to live parts. The interior of the enclosure must be accessible only by the use of a tool. Subsequent sections of this publication may contain additional information regarding specific enclosure type ratings that are required to comply with certain product safety certifications.



See NEMA Standards publication 250 and IEC publication 60529, as applicable, for explanations of the degrees of protection provided by different types of enclosures.

ATTENTION**Preventing Electrostatic Discharge**

This equipment is sensitive to electrostatic discharge, which can cause internal damage and affect normal operation. Follow these guidelines when you handle this equipment:

- Touch a grounded object to discharge potential static.
- Wear an approved grounding wriststrap.
- Do not touch connectors or pins on component boards.
- Do not touch circuit components inside the equipment.
- If available, use a static-safe workstation.
- When not in use, keep modules in appropriate static-safe packaging.

Safety Approvals

<p>The following information applies when operating this equipment in hazardous locations.</p>	<p>Informations sur l'utilisation de cet équipement en environnements dangereux.</p>
<p>Products marked "CL I, DIV 2, GP A, B, C, D" are suitable for use in Class I Division 2 Groups A, B, C, D, Hazardous Locations and nonhazardous locations only. Each product is supplied with markings on the rating nameplate indicating the hazardous location temperature code. When combining products within a system, the most adverse temperature code (lowest "T" number) may be used to help determine the overall temperature code of the system. Combinations of equipment in your system are subject to investigation by the local Authority Having Jurisdiction at the time of installation.</p>	<p>Les produits marqués "CL I, DIV 2, GP A, B, C, D" ne conviennent qu'à une utilisation en environnements de Classe I Division 2 Groupes A, B, C, D dangereux et non dangereux. Chaque produit est livré avec des marquages sur sa plaque d'identification qui indiquent le code de température pour les environnements dangereux. Lorsque plusieurs produits sont combinés dans un système, le code de température le plus défavorable (code de température le plus faible) peut être utilisé pour déterminer le code de température global du système. Les combinaisons d'équipements dans le système sont sujettes à inspection par les autorités locales qualifiées au moment de l'installation.</p>
<p>WARNING</p> 	<p>EXPLOSION HAZARD -</p> <ul style="list-style-type: none"> • Do not disconnect equipment unless power has been removed or the area is known to be nonhazardous. • Do not disconnect connections to this equipment unless power has been removed or the area is known to be nonhazardous. Secure any external connections that mate to this equipment by using screws, sliding latches, threaded connectors, or other means provided with this product. • Substitution of components may impair suitability for Class I, Division 2. • If this product contains batteries, they must only be changed in an area known to be nonhazardous.
<p>AVERTISSEMENT</p> 	<p>RISQUE D'EXPLOSION –</p> <ul style="list-style-type: none"> • Couper le courant ou s'assurer que l'environnement est classé non dangereux avant de débrancher l'équipement. • Couper le courant ou s'assurer que l'environnement est classé non dangereux avant de débrancher les connecteurs. Fixer tous les connecteurs externes reliés à cet équipement à l'aide de vis, loquets coulissants, connecteurs filetés ou autres moyens fournis avec ce produit. • La substitution de composants peut rendre cet équipement inadapté à une utilisation en environnement de Classe I, Division 2. • S'assurer que l'environnement est classé non dangereux avant de changer les piles.

IMPORTANT

Wiring to or from this device, which enters or leaves the system enclosure, must utilize wiring methods suitable for Class I, Division 2 Hazardous Locations, as appropriate for the installation in accordance with the product drawings as indicated in the following table.

Model	Catalog Number	Haz Location Drawings*	
		w/o Barriers	w/ Barriers
XM-120	1440-VST0201RA	48178-HAZ	48179-HAZ
XM-121	1440-VLF0201RA		
XM-122	1440-VSE0201RA		
XM-123	1440-VAD0201RA		
XM-160	1440-VDRS0600RH	51263-HAZ	51264-HAZ
XM-161	1440-VDRS0606RH		
XM-162	1440-VDRP0600RH		
XM-220	1440-SPD0201RB	48640-HAZ	48641-HAZ
XM-320	1440-TPS0201RB	48238-HAZ	48239-HAZ
XM-360	1440-TPR0600RE	48295-HAZ	48299-HAZ
XM-361	1440-TUN0600RE		
XM-361	1440-TTC0600RE		
XM-440	1440-RMA0004RC	48240-HAZ	N/A
XM-441	1440-REX0004RD	48241-HAZ	N/A
XM-442	1440-REX0304RG	48642-HAZ	N/A

* Drawings are available on the included CD

6 XM-942 Master Relay Terminal Base

European Zone 2 Certification

If appropriately marked, this equipment is intended for use in potentially explosive atmospheres as defined by European Union Directive 94/9/CE.

Compliance with the Essential Health and Safety Requirements has been assured by compliance with EN 50021 (1999).

IMPORTANT

Observe the following additional Zone 2 certification requirements:

- This equipment is not resistant to sunlight or other sources of UV radiation.
 - The secondary of a current transformer shall not be open-circuited.
 - The marking "ALCR" is to be considered "as applicable" to individual products.
 - Equipment of lesser Enclosure Type Rating must be installed in an enclosure providing at least IP54 protection when applied in Class I, Zone 2 environments.
 - This equipment must be powered by energy limited associated equipment as defined in EN 50021 when applied in Class I, Zone 2 environments.
 - Provision shall be made to prevent the rated voltage from being exceeded by transient disturbances of more than 40% when applied in Class I, Zone 2 environments.
-

Power Requirements

Power Supply

Requires a 24Vdc ($\pm 10\%$) power source per the following table.

XM Power Supply Requirements

Protection	Listed Class 2 rated supply, or
	Fused* ITE Listed SELV supply, or
	Fused* ITE Listed PELV supply
Output Voltage	24Vdc $\pm 10\%$

Output Power	100 Watts Maximum (~4A @ 24Vdc)
Static Regulation	± 2%
Dynamic Regulation	± 3%
Ripple	< 100mVpp
Output Noise	Per EN50081-1
Overshoot	< 3% at turn-on, < 2% at turn-off
Hold-up Time	As required (typically 50mS at full rated load)

* When a fused supply is used the fuse must be a 5 amp, listed, fast acting fuse such as provided by Allen-Bradley part number 1440-5AFUSEKIT.

Refer to the specifications for the specific module for power consumption and other requirements.

See XM Power Supply Solutions application technique, publication ICM-AP005A-EN-E, for additional details.

Interconnect Limit

Total current draw through the side connector cannot exceed 3A. A separate power connection is necessary if the total current draw of the interconnecting modules is greater than 3A.

TIP

If the total current draw for a row of modules is greater than 3A, consider connecting power to a module near the center of the rail, rather than at a module on either end. Insure that there is less than 3A load in either direction from the module where power is connected.

Wiring Requirements

Use solid or stranded wire. All XM wiring should meet the following specifications:

8 XM-942 Master Relay Terminal Base

- 14 to 22 AWG copper conductors without pretreatment; 8 AWG required for grounding the DIN rail for electromagnetic interference (emi) purposes
- Recommended strip length 8 millimeters (0.31 inches)
- Minimum insulation rating of 300V
- Soldering the conductor is forbidden
- Wire ferrules can be used with stranded conductors; copper ferrules recommended

ATTENTION

See the XM Documentation and Configuration Utility CD for Hazardous Locations installation drawings. The XM Documentation and Configuration Utility CD is packaged with the XM modules.

Grounding Requirements

Use these grounding requirements to ensure safe electrical operating circumstances, and to help avoid potential emi and ground noise that can cause unfavorable operating conditions for your XM system.

DIN Rail Grounding

The XM modules make a chassis ground connection through the DIN rail. The DIN rail must be connected to a ground bus or grounding electrode conductor using 8 AWG or 1 inch copper braid. See illustration on the following page.

Use zinc-plated, yellow-chromated steel DIN rail (Allen-Bradley part no. 199-DR1 or 199-DR4) or equivalent to assure proper grounding. Using other DIN rail materials (e.g. aluminum, plastic, etc.), which can corrode, oxidize, or are poor conductors can result in improper or intermittent platform grounding.

XM System DIN Rail Grounding

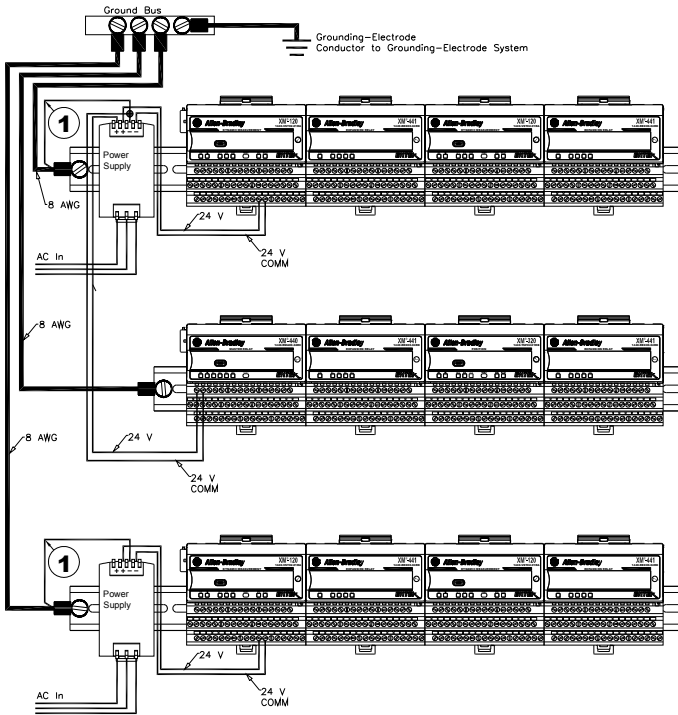

- 1 Use 14 AWG wire.

10 XM-942 Master Relay Terminal Base

The grounding wire can be connected to the DIN rail using a DIN Rail Grounding Block (see illustration below).

DIN Rail Grounding Block

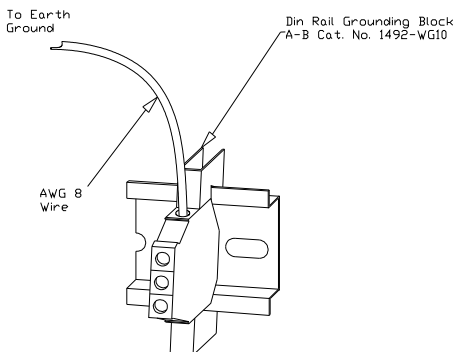

24V Common Grounding

24V to the XM module must be grounded. When two or more power supplies power the XM system, ground the 24 V Commons at a single point, such as the ground bus bar.

IMPORTANT

If it is not possible or practical to ground the -24Vdc supply, then it is possible for the system to be installed and operate ungrounded. However, if installed ungrounded then the system must not be connected to a ground through any other circuit unless that circuit is isolated externally. Connecting a floating system to a non-isolated ground could result in damage to the XM module(s) and/or any connected device. Also, operating the system without a ground may result in the system not performing to the published specifications regards measurement accuracy and communications speed, distance or reliability.

IMPORTANT

The 24V Common and Signal Common terminals are internally connected. They are isolated from the Chassis terminals unless they are connected to ground as described in this manual. See Wiring on page 15 for terminal assignments.

Transducer Grounding

Make certain the transducers are electrically isolated from earth ground. Cable shields must be grounded at one end of the cable, and the other end left floating or not connected. It is recommended that where possible, the cable shield be grounded at the XM terminal base (Chassis terminal) and not at the transducer.

DeviceNet Grounding

The DeviceNet network is functionally isolated and must be referenced to earth ground at a single point. XM modules can not be used with an external DeviceNet power supply. Connect DeviceNet V- to earth ground at one of the XM modules, as shown in the illustration below.

Grounded DeviceNet V- at XM Module

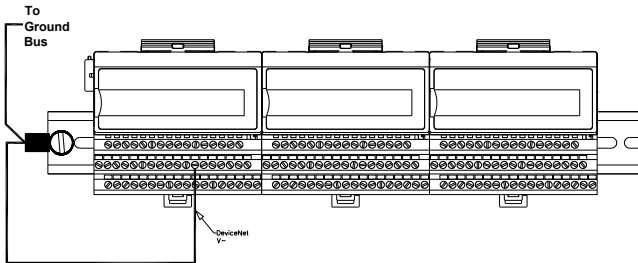

ATTENTION



Use of a separate DeviceNet power supply is not permitted. See Application Technique "XM Power Supply Solutions", publication ICM-AP005A-EN-E, for guidance in using XM with other DeviceNet products.

For more information on the DeviceNet installation, refer to the ODVA Planning and Installation Manual - DeviceNet Cable System, which is available on the ODVA web site (<http://www.odva.org>).

Switch Input Grounding

The Switch Input circuits are functionally isolated from other circuits. It is recommended that the Switch RTN signal be grounded at a single point. Connect the Switch RTN signal to the XM terminal base (Chassis terminal) or directly to the DIN rail, or ground the signal at the switch or other equipment that is wired to the switch.

Mounting on the DIN Rail

You can also mount the terminal base to a grounded mounting plate. Refer to the XM Module User Guide for details.

ATTENTION



The XM-942 makes a chassis ground connection through the DIN rail. Use zinc plated, yellow chromated steel DIN rail to assure proper grounding. Using other DIN rail materials (e.g. aluminum, plastic, etc.) which can corrode, oxidize or are poor conductors can result in improper or intermittent platform grounding.

1. Position the terminal base unit on the 35 x 7.5mm DIN rail (A) (A-B pt no. 199-DR1 or 199-DR4) at a slight angle.

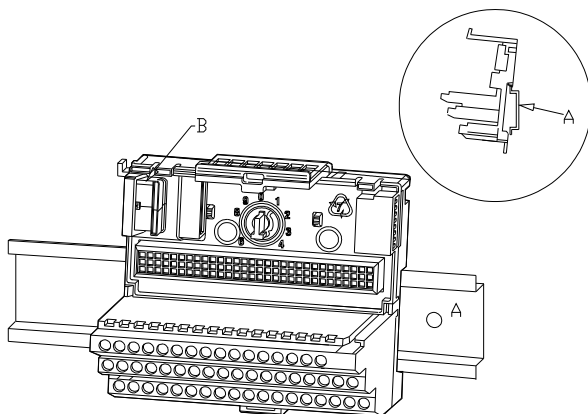

Position terminal base at a slight angle and hook over the top of the DIN rail.

2. Slide the terminal base unit over leaving room for the side connector (B).
3. Hook the lip on the rear of the terminal base onto the top of the DIN rail, and rotate the terminal base onto the rail.

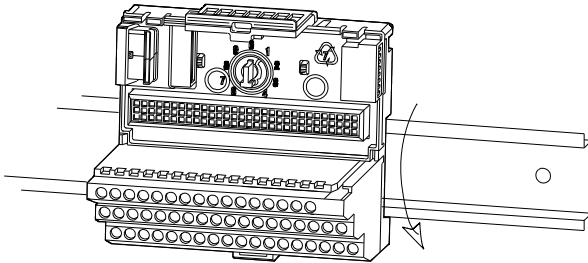

4. Press down on the terminal base unit to lock the terminal base on the DIN rail. If the terminal base does not lock into place, use a screwdriver or similar device to open the locking tab, press down on the terminal base until flush with the DIN rail and release the locking tab to lock the base in place.
5. Connect the wiring for the XM-942 terminal base unit as shown under Wiring later in this document.

Interconnecting Terminal Base Units

Follow the steps below to install another terminal base unit.

IMPORTANT

Terminal base units are mounted left to right on the DIN rail.

1. Position the terminal base on the 35 x 7.5mm DIN rail (A).
2. Make certain the side connector (B) is **fully retracted** into the base unit.

14 XM-942 Master Relay Terminal Base

3. Slide the terminal base unit over tight against the neighboring terminal base. Make sure the hook on the terminal base slides under the edge of the terminal base unit.
4. Press down on the terminal base unit to lock the terminal base on the DIN rail. If the terminal base does not lock into place, use a screwdriver or similar device to open the locking tab, press down on the terminal base until flush with the DIN rail and release the locking tab to lock the base in place.
5. Gently push the side connector into the side of the neighboring terminal base to complete the backplane connection.

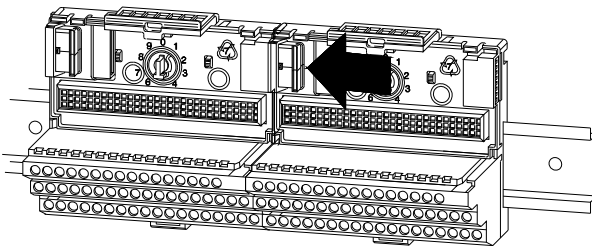

Wiring

0	1	2	3	4	5	6	7	8	9	10	11	12	13	14	15			
																Row A		
16	17	18	19	20	21	22	23	24	25	26	27	28	29	30	31	32	33	
																Row B		
34	35	36	37	38	39	40	41	42	43	44	45	46	47	48	49	50	51	
																Row C		

IMPORTANT

For more wiring connection information, refer to the XM Module User Guide.

Terminal Assignments

WARNING

EXPLOSION HAZARD

Do not disconnect equipment unless power has been removed or the area is known to be nonhazardous.

Do not disconnect connections to this equipment unless power has been removed or the area is known to be nonhazardous. Secure any external connections that mate to this equipment by using screws, sliding latches, threaded connectors, or other means provided with this product.

ATTENTION

The terminal block assignments are different for different terminal base units. The following table applies only to the XM-942. Refer to the installation instructions for the specific terminal base unit for its terminal assignments.

No.	Description	No.	Description
0	24V in	26	No connection
1	24V common	27	Relay 3 common contact 1
2	Reset relay	28	Relay 4 common contact 2
3	Reserved	29	Relay 4 common contact 1
4	Relay 1 N.O. contact 2	30	No connection

16 XM-942 Master Relay Terminal Base

No.	Description	No.	Description
5	Relay 1 N.O. contact 1	31	Chassis
6	Relay 2 N.O. contact 2	32	DeviceNet V (+) (red wire) (Optional, see IMPORTANT note below)
7	No connection	33	CAN_High (white wire)
8	Relay 2 N.O. contact 1	34	RxD
9	Relay 3 N.O. contact 2	35	No connection
10	No connection	36	No connection
11	Relay 3 N.O. contact 1	37	No connection
12	Relay 4 N.O. contact 2	38	Relay 1 N.C. contact 2
13	Relay 4 N.O. contact 1	39	Relay 1 N.C. contact 1
14	No connection	40	Relay 2 N.C. contact 2
15	Chassis	41	No connection
16	TxD	42	Relay 2 N.C. contact 1
17	XRTN	43	Relay 3 N.C. contact 2
18	Switch RTN	44	No connection
19	24V out (Diode-ORed output DO NOT CONNECT)	45	Relay 3 N.C. contact 1
20	Relay 1 common contact 2	46	Relay 4 N.C. contact 2
21	Relay 1 common contact 1	47	Relay 4 N.C. contact 1
22	Relay 2 common contact 2	48	No connection
23	No connection	49	Chassis
24	Relay 2 common contact 1	50	DeviceNet V (-) (black wire)
25	Relay 3 common contact 2	51	CAN_Low (blue wire)

IMPORTANT

The DeviceNet power circuit through the XM module interconnect, which is rated at only 300mA, is not intended or designed to power DeviceNet loads. Doing so could damage the module or terminal base.

To preclude this possibility, even unintentionally, it is recommended that DeviceNet V+ be left unconnected.

Agency Certification (when product marked)

UL	UL Listed for Ordinary Locations
UL	UL Listed for Class I, Division 2 Group A, B, C, and D Hazardous Locations
CSA	CSA Certified Process Control Equipment
CSA	CSA Certified Process Control Equipment for Class I, Division 2 Group A, B, C, and D Hazardous Locations
EEX ¹	European Union 94/9/EEC ATEX Directive, compliant with EN 50021; Potentially Explosive Atmospheres, Protection “n”
CE ¹	European Union 89/336/EEC EMC Directive
C-Tick ¹	Australian Radiocommunications Act, compliant with: AS/NZS 2064, Industrial Emissions

¹ See the Product Certification link at www.rockwellautomation.com for Declarations of Conformity, Certificates and other certification details.

Specifications

The following table lists the technical specifications for the XM-942 Master Relay Terminal Base.

Product Feature	Specification
Power	
Module	+21.6 to +26.4V dc
Consumption	200 mA maximum
Heat Production	3.4 Watts (11.6 BTU/Hr) maximum
Environmental	
Operating Temperature	-20 to +65°C (-4 to +149°F)
Storage Temperature	-40 to +85°C (-40 to +185°F)
Relative Humidity	95% non-condensing
Conformal Coating	All printed circuit boards are conformally coated in accordance with IPC-A-610C.
Physical	
Dimensions	3.875 W x 3.75 D x 2.25 H inches 9.48 W x 9.53 D x 5.72 H centimeters
Terminal Screw Torque	7 pound-inches (0.6 Nm)

Note: Power specification is with module installed.

Rockwell Automation Support

Rockwell Automation provides technical information on the Web to assist you in using its products. At <http://www.rockwellautomation.com/support/>, you can find technical manuals, a knowledge base of FAQs, technical and application notes, sample code and links to software service packs, and a MySupport feature that you can customize to make the best use of these tools.

For an additional level of technical phone support for installation, configuration, and troubleshooting, we offer TechConnect support programs. For more information, contact your local distributor or Rockwell Automation representative, or visit <http://www.rockwellautomation.com/support/>.

Installation Assistance

If you experience a problem within the first 24 hours of installation, please review the information that's contained in this manual. You can also contact a special Customer Support number for initial help in getting your product up and running.

United States or Canada	1.440.646.3434
Outside United States or Canada	Use the Worldwide Locator at http://www.rockwellautomation.com/support/americas/phone_en.html , or contact your local Rockwell Automation representative.

New Product Satisfaction Return

Rockwell Automation tests all of its products to ensure that they are fully operational when shipped from the manufacturing facility. However, if your product is not functioning and needs to be returned, follow these procedures.

United States	Contact your distributor. You must provide a Customer Support case number (call the phone number above to obtain one) to your distributor to complete the return process.
Outside United States	Please contact your local Rockwell Automation representative for the return procedure.

Documentation Feedback

Your comments will help us serve your documentation needs better. If you have any suggestions on how to improve this document, complete this form, publication [BA-DU002](#), available at <http://literature.rockwellautomation.com>.

Allen-Bradley, Rockwell Software, Rockwell Automation, and XM are trademarks of Rockwell Automation, Inc.

Trademarks not belonging to Rockwell Automation are property of their respective companies.

www.rockwellautomation.com

Power, Control and Information Solutions Headquarters

Americas: Rockwell Automation, 1201 South Second Street, Milwaukee, WI 53204 USA, Tel: (1) 414.382.2000, Fax: (1) 414.382.4444
Europe/Middle East/Africa: Rockwell Automation, Vorstlaan/Boulevard du Souverain 36, 1170 Brussels, Belgium, Tel: (32) 2 663 0600, Fax: (32) 2 663 0640
Asia Pacific: Rockwell Automation, Level 14, Core F, Cyberport 3, 100 Cyberport Road, Hong Kong, Tel: (852) 2887 4788, Fax: (852) 2508 1846

Publication GMSI10-IN022A-EN-P - May 2010

PN-71168

Supersedes Publication GMSI10-UM022A-EN-E - January 2006 Copyright © 2010 Rockwell Automation, Inc. All rights reserved. Printed in the U.S.A.